



PAOLONESI
F I R E N Z E 1 9 6 2

/CraftWAVES
not ordinary

R

Quando l'obiettivo
è quello di cambiare
vita, il design è in
primo piano.

Paolo Nesi

Index.

The background features a complex, abstract composition of textures and colors. A deep blue, fine-grained fabric-like texture dominates the right side and bottom. On the left, a lighter, more uniform blue texture is visible. A vibrant purple line curves from the top center towards the middle right. A brown, leather-like curved line runs from the bottom left towards the center. The overall effect is one of layered, tactile surfaces.



/01 **Storia**

Paolo Nesi
Giuseppe Di Cecca
Francesca Nesi

/02 **CraftWAVES**

Prima collezione

/03 **Prodotti**

Ti Amo / outdoor (gialla)
Ti Amo / outdoor (gialla e blu)
Ti Amo / indoor
Snaked
Mistake
Jimmy

1962

Storia



del lusso

Fondata nel 1962 dalla famiglia Nesi è sempre stata un punto di riferimento per la tappezzeria di lusso in tutta la Toscana. Attraverso gli anni sono stati custoditi e mantenuti i segreti della produzione artigianale senza però mai smettere di investire nello sviluppo tecnologico. Ogni creazione viene trasformata in un'opera dal valore culturale e sociale, sintesi di un sapere tramandato da più mani e voci.

È l'unica realtà del centro Italia che possa garantire consistenti livelli di produzione di altissima qualità, dal 2020 si presenta come la prima tappezzeria costum in Italia certificata ISO 9001. I collaboratori interni sono tutti artigiani toscani di grande esperienza, nati e cresciuti all'interno della grande tradizione artigianale italiana. Il prodotto è orgogliosamente 100% MADE IN ITALY. Per molti anni sono stati fatti investimenti in nuovi network vendite volti a migliorare e dare potenzialità ai prodotti, con la grande ambizione di posizionarsi nel mercato dell'arredamento come uno dei brand più importanti a livello internazionale. Su questo progetto è stata estesa la rete vendite con agenti in Nord Europa, Sud Europa, Africa e Medio Oriente.

Artigiani

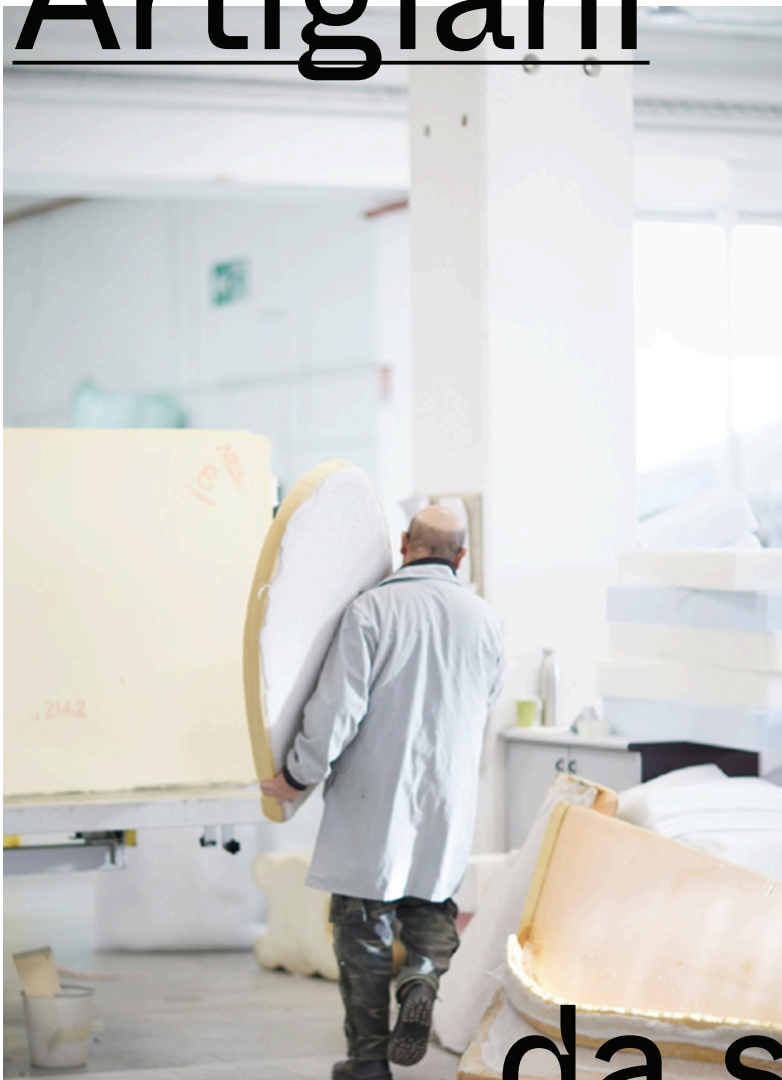

da sempre

Paolo Nesi, un visionario nell'universo dell'imprenditoria tessile.

Paolo ha mosso i primi passi nel mondo degli affari nel negozio di famiglia a Poggibonsi, dove suo padre vendeva tessuti e sua madre confezionava tendaggi su misura.

Fin dalla giovane età, Paolo ha dimostrato una determinazione straordinaria: a soli 18 anni, ha acquistato un furgone e attrezzature per l'installazione, dimostrando le sue abilità imprenditoriali emergenti.

La sua ambizione lo ha spinto a fondare la Paolo Nesi Srl, trasformando il piccolo negozio di famiglia in una vera e propria azienda di successo nel settore del design tessile.

Motivato dalla costante sfida di superare se stesso, Paolo ha posto l'obiettivo di far crescere il marchio Paolo Nesi a livello globale, attraverso una combinazione di creatività, innovazione e impegno incessante.

Le sfide non sono mancate lungo il percorso di Paolo.

Con l'introduzione di nuove tecnologie industriali e collaborazioni con partner creativi come Giuseppe Dicecca, ogni ostacolo è stato affrontato con risolutezza e determinazione.

Oltre al successo commerciale, Paolo è impegnato a promuovere una visione sostenibile e responsabile. La Paolo Nesi Srl si impegna attivamente per diventare completamente ecocompatibile entro il 2026, adottando pratiche ecosostenibili e riducendo l'impatto ambientale.

/Ceo and Founder



**Paolo
Nesi**

Giuseppe Dicecca



/Designer

Giuseppe Dicecca, figura di spicco nel mondo del design, noto per la sua straordinaria creatività e innovazione.

Dopo una carriera nel mondo dello spettacolo e della moda, Giuseppe ha abbracciato il design d'interni e la creazione di prodotti, ispirandosi alla moda, all'arte e alla natura.

La sua collaborazione con Paolo Nesi è stata un incontro di menti creative, portando a progetti unici che riflettono passione e dedizione.

Le creazioni di Giuseppe sono caratterizzate da linee curve, colori pastello e materiali riciclati, esprimendo la sua visione di un design elegante e sostenibile.

Guardando al futuro, Giuseppe immagina un design guidato dall'innovazione materica, dalla multifunzionalità e dall'ecosostenibilità, impegnato a plasmare un mondo migliore per le generazioni future.

Francesca Nesi



/Worldwide Commercial Director

Francesca Nesi, la nostra Worldwide Commercial Director. Con la sua visione globale e il suo innato talento per il business, Francesca guida il nostro settore commerciale con passione e determinazione.

Grazie alla sua leadership, siamo in grado di espandere il nostro marchio a livello internazionale, portando l'eccellenza del nostro arredamento di lusso in tutto il mondo.



CraftWAVES

/Not Ordinary.



CraftWAVES

CraftWAVE rappresenta l'emozionante presentazione della prima collezione di Paolo Nesi. Un viaggio nelle influenze pop, un viaggio che esplora stile e creatività attraverso affascinanti contrasti. Paolo Nesi conduce la sua visione del soft living attraverso le opere uniche del designer Giuseppe Dicecca. Insieme esploriamo le forme intriganti di poltrone e divani, scoprendo una combinazione unica di design e comfort.



Prodotto

TiAmo /outdoor





**DESIGN
GIUSEPPE DICECCA**

/CARATTERISTICHE

La poltrona Tiamo, pensata sia per indoor che per outdoor, è un connubio di confort e giocosità, le sue linee morbide e tondeggianti e suoi colori accesi e dal sapore vintage racchiudono un concept estremamente pop e contemporaneo. Per l'Outdoor il suo confort è curato e reso unico dalla gommapiuma Dryfeel®.

Dryfeel® è una gommapiuma a struttura cellulare completamente aperta che consente all'acqua e all'umidità di passarvi attraverso in modo rapido ed efficace, assicurando il massimo confort in ogni condizione di umidità.

Come tessuto tecnico si è scelto il massimo dell'ecosostenibilità sostenendo Reviva che, attraverso un processo meccanico, ricicla bottiglie di plastica che vengono trasformate in polimeri e successivamente in filato 100% riciclato e 100% riciclabile.

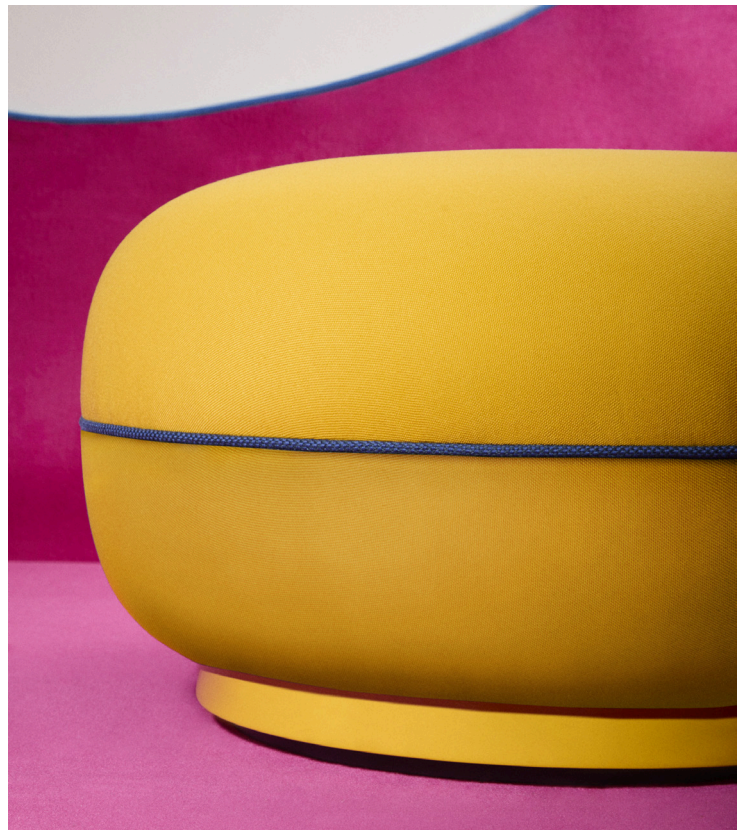
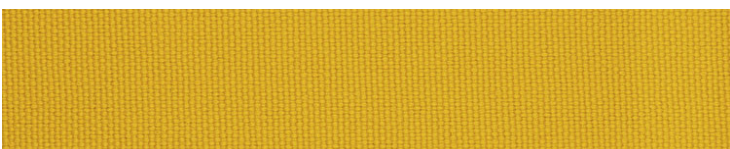



Materiali & Colori

FLAMING STAR

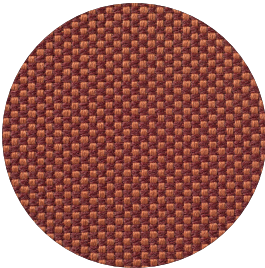

REV200
302

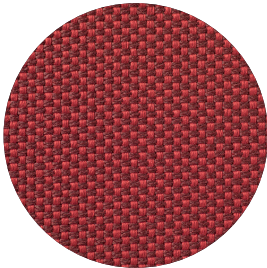

REV200
306

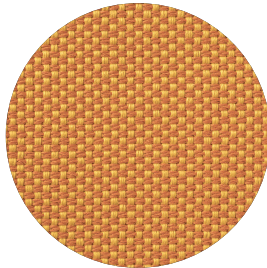

REV200
308

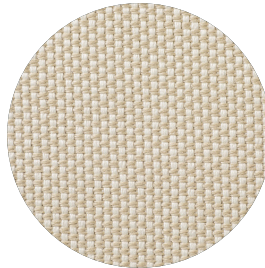

REV200
403

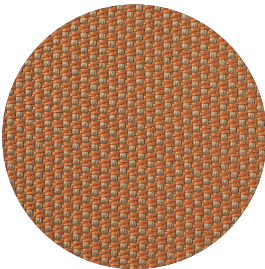

REV200
404

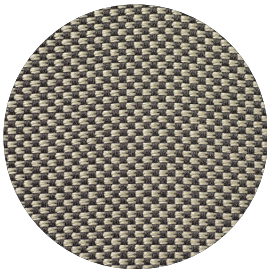

REV200
406

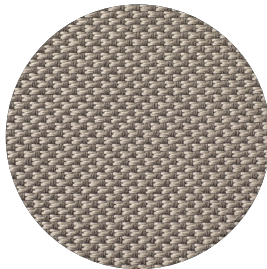

REV200
603

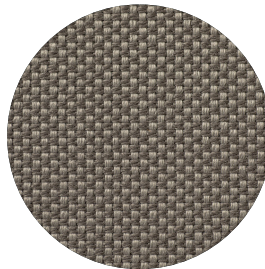

REV200
604

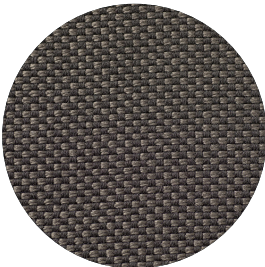

REV200
605

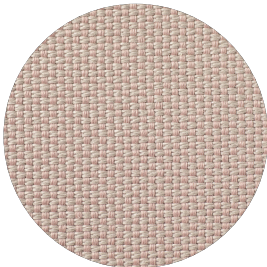

REV200
607

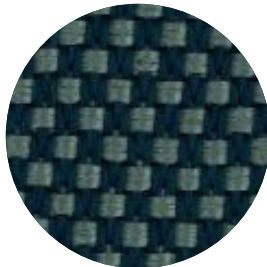

REV200
703



REV200
704

Materiali & Colori

MY WAY

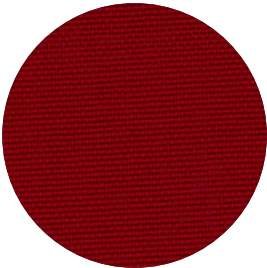

REV100
305

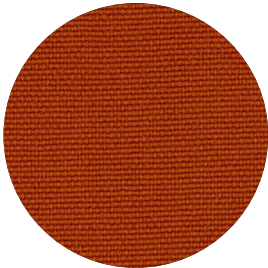

REV100
307



REV100
401



REV100
402



REV100
610

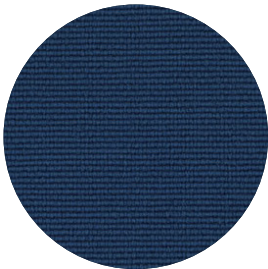

REV100
701

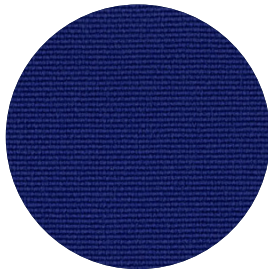

REV100
705

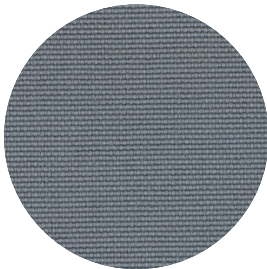

REV100
711

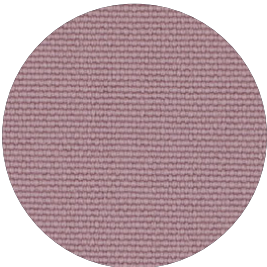

REV100
901



REV100
100

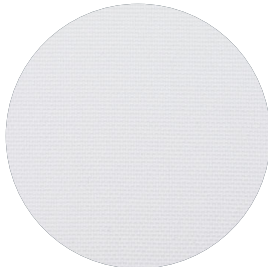

REV100
111

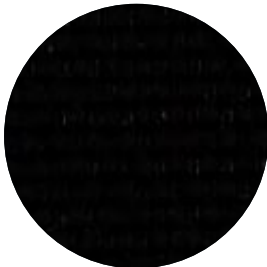

REV100
200

Materiali & Colori

MY WAY



REV100
303



REV100
304



REV100
414



REV100
415

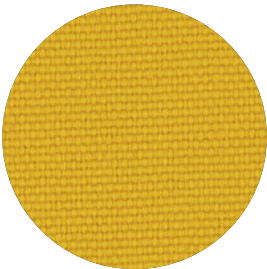

REV100
501

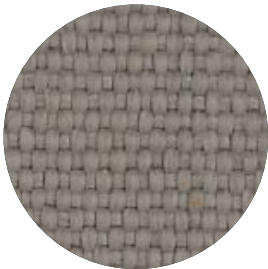

REV100
601

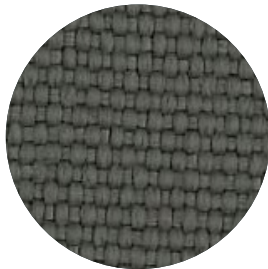

REV100
602



REV100
706

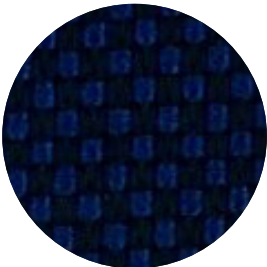

REV100
707



REV100
801

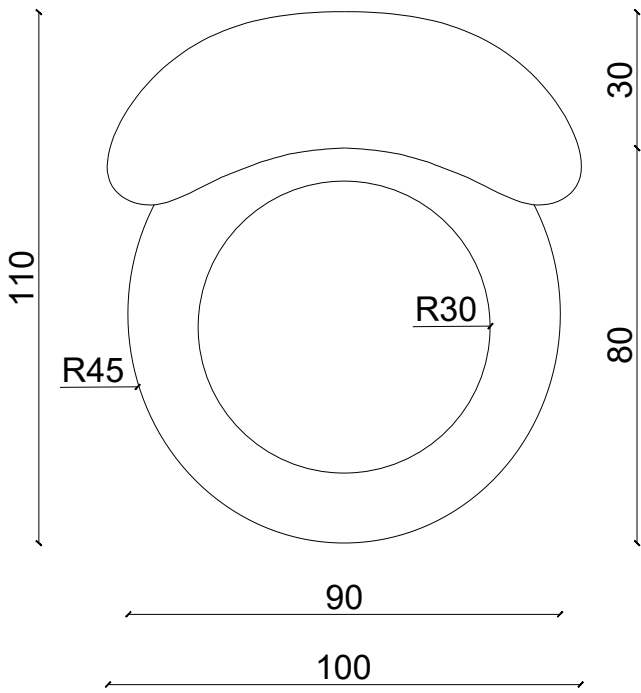
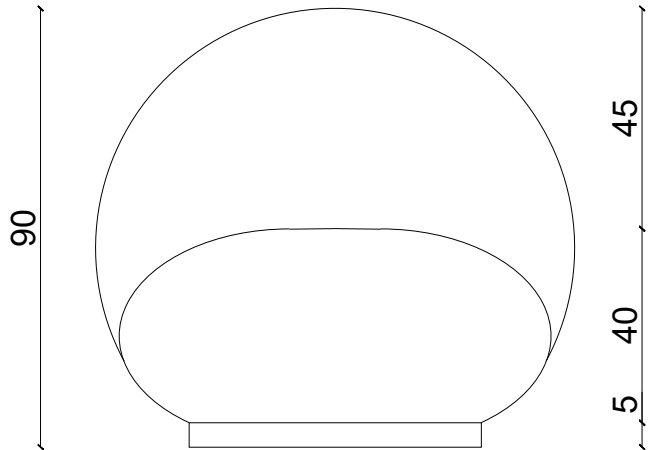
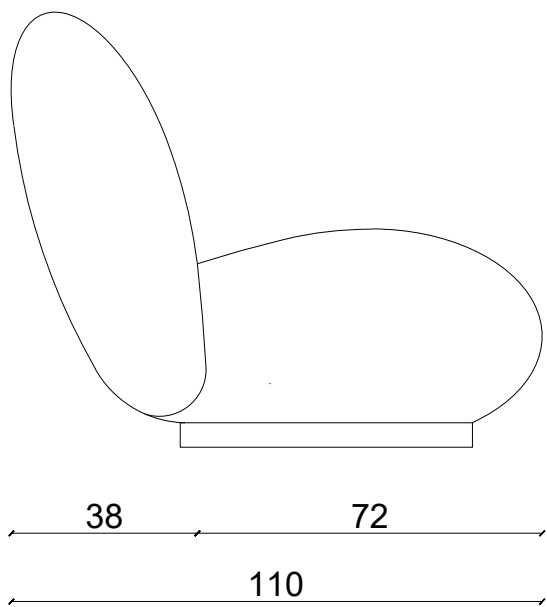

Prodotto

TiAmo /outdoor



**DESIGN
GIUSEPPE DICECCA**

/CARATTERISTICHE

La poltrona Tiamo, pensata sia per indoor che per outdoor, è un connubio di confort e giocosità, le sue linee morbide e tondeggianti e suoi colori accesi e dal sapore vintage racchiudono un concept estremamente pop e contemporaneo. Per l'Outdoor il suo confort è curato e reso unico dalla gommapiuma Dryfeel®.

Dryfeel® è una gommapiuma a struttura cellulare completamente aperta che consente all'acqua e all'umidità di passarvi attraverso in modo rapido ed efficace, assicurando il massimo confort in ogni condizione di umidità.

Come tessuto tecnico si è scelto il massimo dell'ecosostenibilità sostenendo Reviva che, attraverso un processo meccanico, ricicla bottiglie di plastica che vengono trasformate in polimeri e successivamente in filato 100% riciclato e 100% riciclabile.

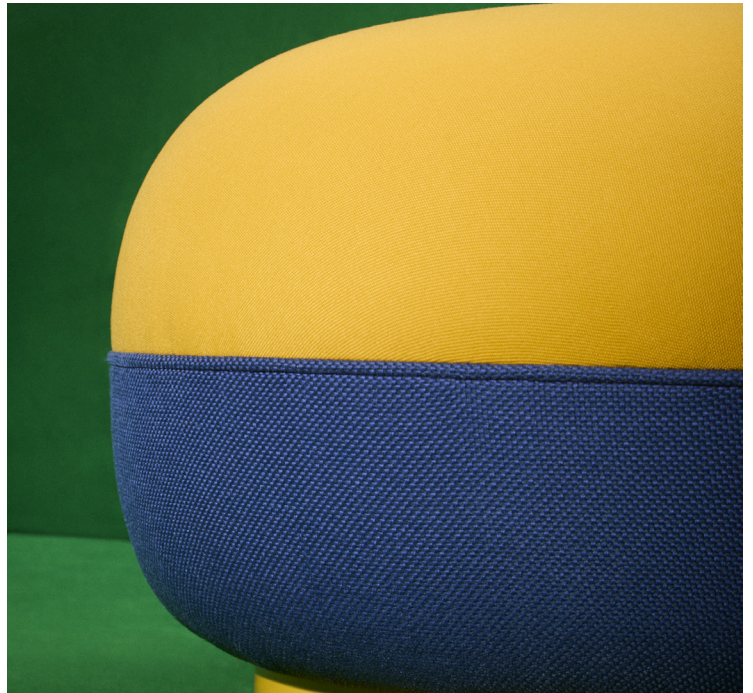
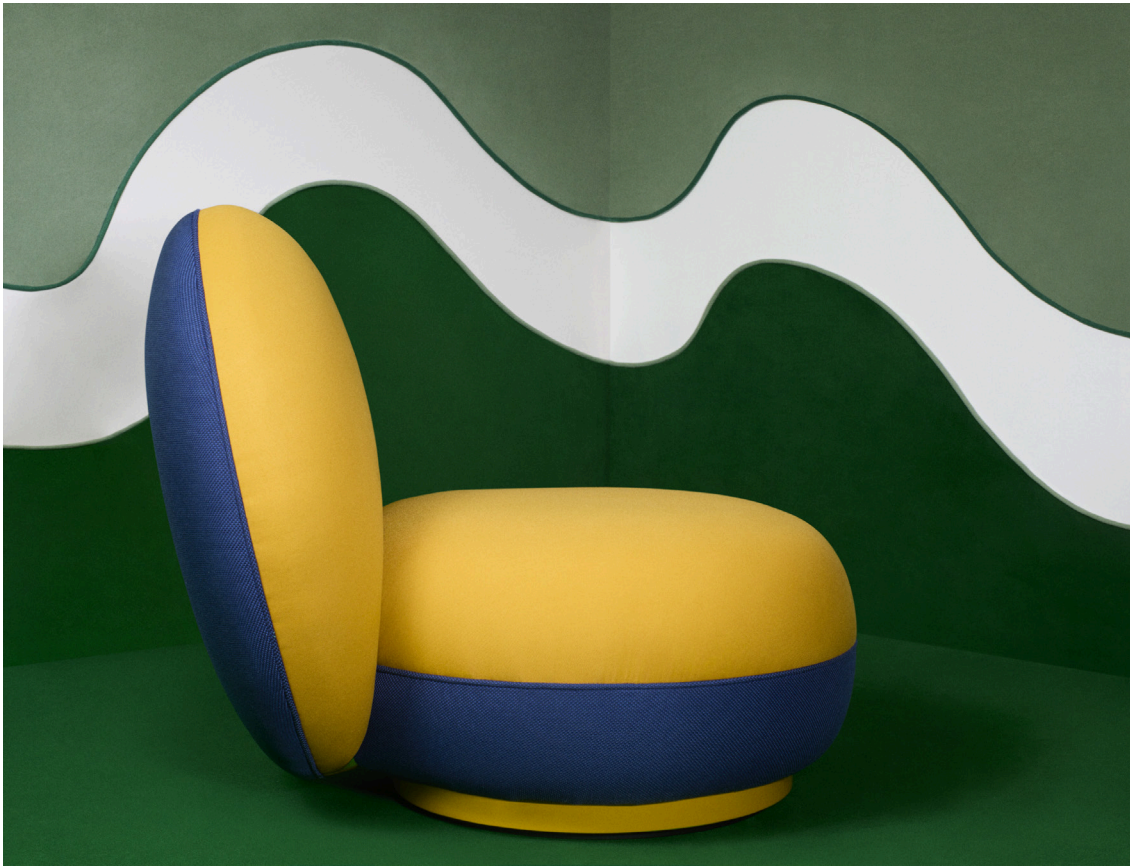



Materiali & Colori

FLAMING STAR

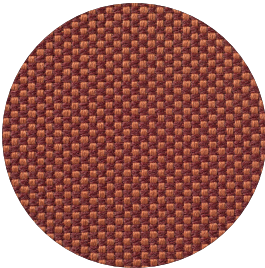

REV200
302

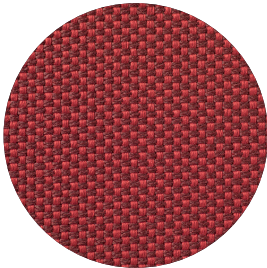

REV200
306

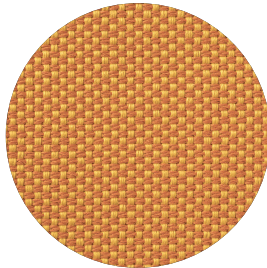

REV200
308

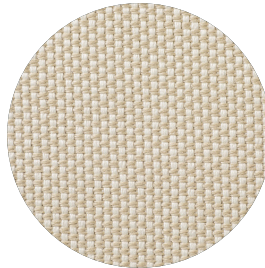

REV200
403

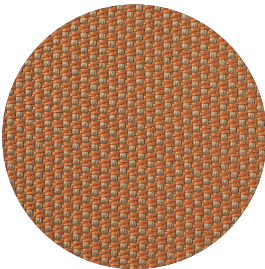

REV200
404

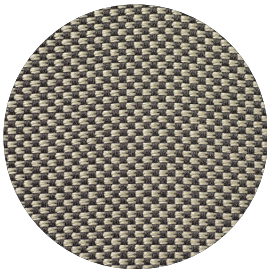

REV200
406

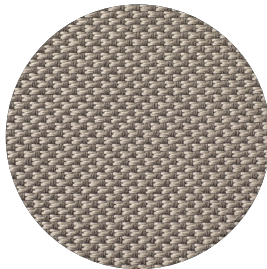

REV200
603

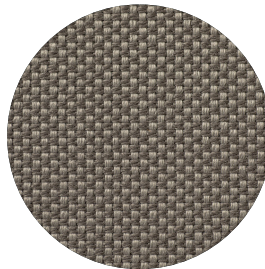

REV200
604

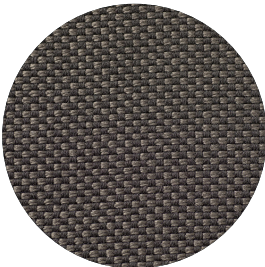

REV200
605

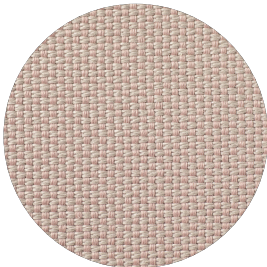

REV200
607

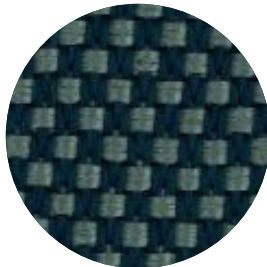

REV200
703



REV200
704

Materiali & Colori

MY WAY



REV100
305

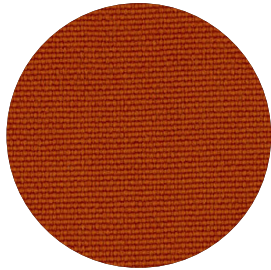

REV100
307



REV100
401



REV100
402



REV100
610



REV100
701

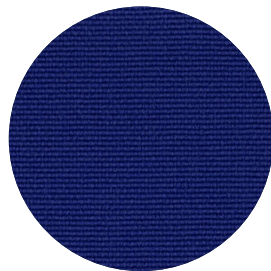

REV100
705

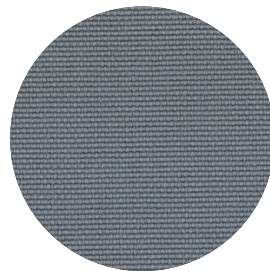

REV100
711

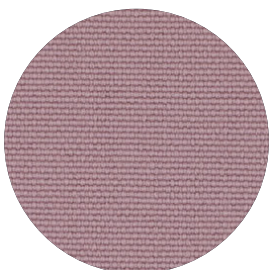

REV100
901



REV100
100

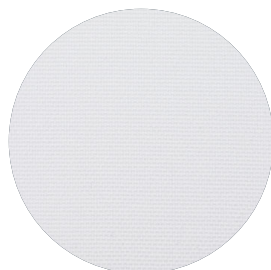

REV100
111

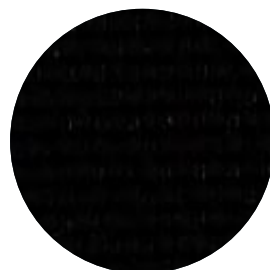

REV100
200

Materiali & Colori

MY WAY



REV100
303



REV100
304



REV100
414



REV100
415

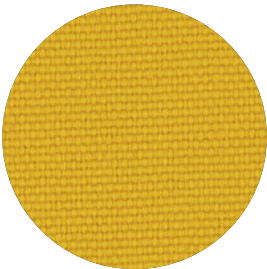

REV100
501

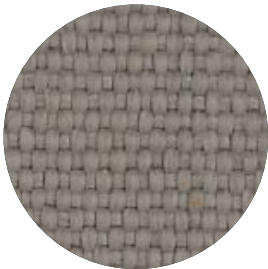

REV100
601

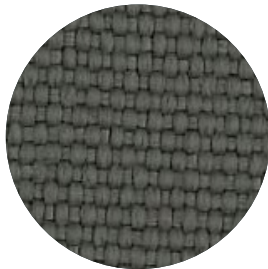

REV100
602



REV100
706

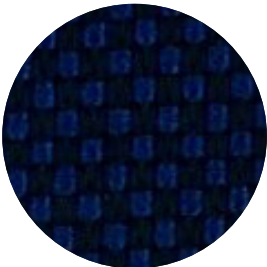

REV100
707



REV100
801

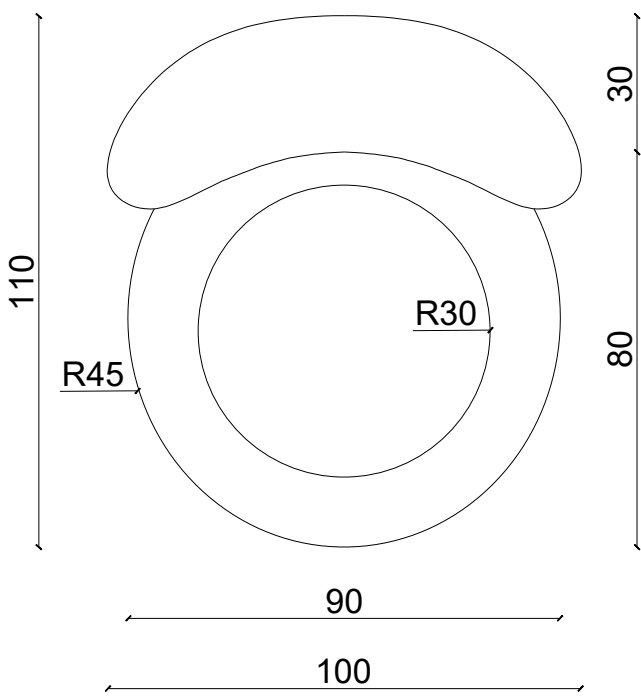
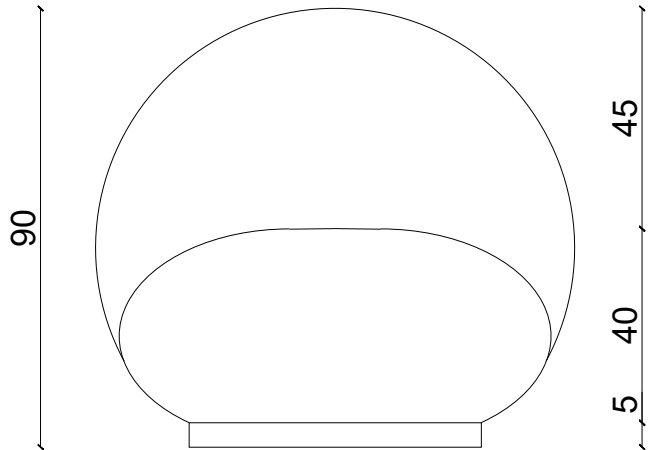
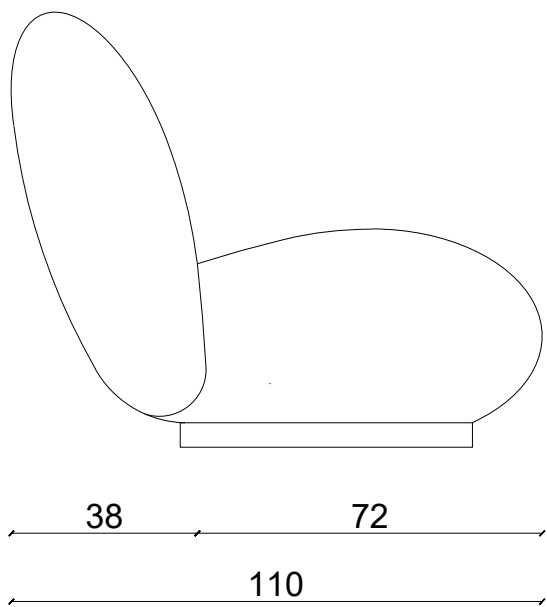

Prodotto

TiAmo /indoor





**DESIGN
GIUSEPPE DICECCA**

/CARATTERISTICHE

La poltrona Tiamo, pensata sia per indoor che per outdoor, è un connubio di comfort e giocosità, le sue linee morbide e tondeggianti e suoi colori accesi e dal sapore vintage racchiudono un concept estremamente pop e contemporaneo. Per l'Indoor il suo comfort è curato da un'eccezionale gommapiuma ecosostenibile prodotta da polioli bio-based ricavati da oli e attivatori vegetali che fungono da alternativa naturale agli agenti chimici nel processo di produzione.

La sua veste è un intrigante mix di due anime: un intrigo materico, un bouclé misto cotone/lana dalle eccezionali sfumature e un morbido velluto dai colori decisi.

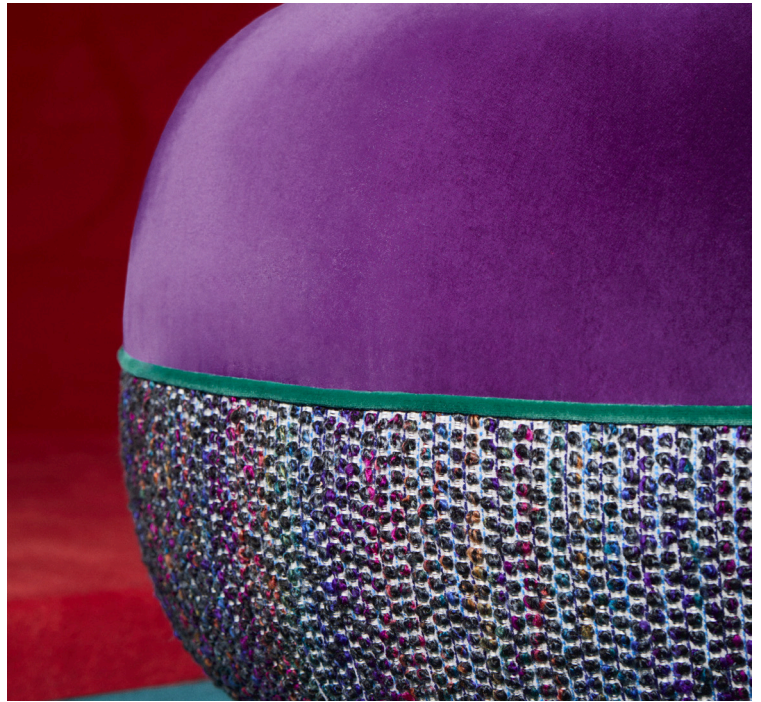



Materiali & Colori

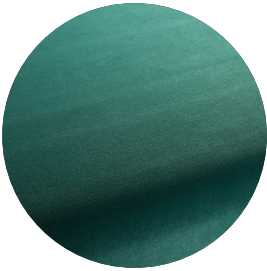

VV1320
034



VV1320
036



VV1320
045

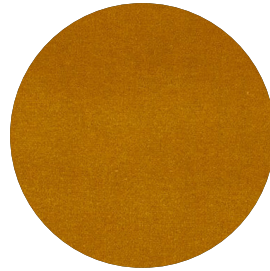

VV1320
048

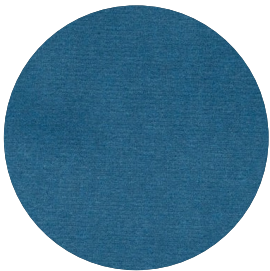

VV1320
053

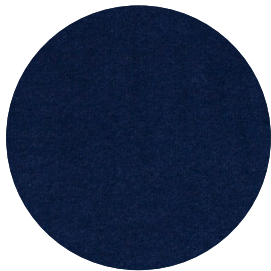

VV1320
055

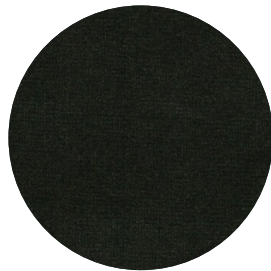

VV1320
083

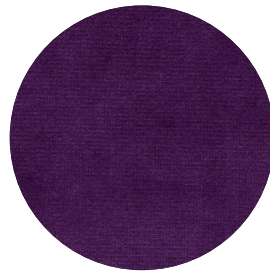

VV1320
085



VV1320
160



VV1320
161



ZM576
05

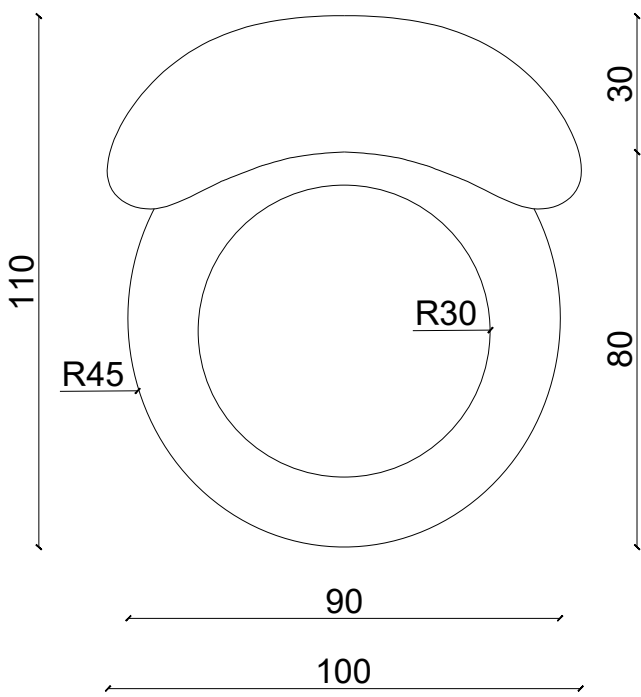
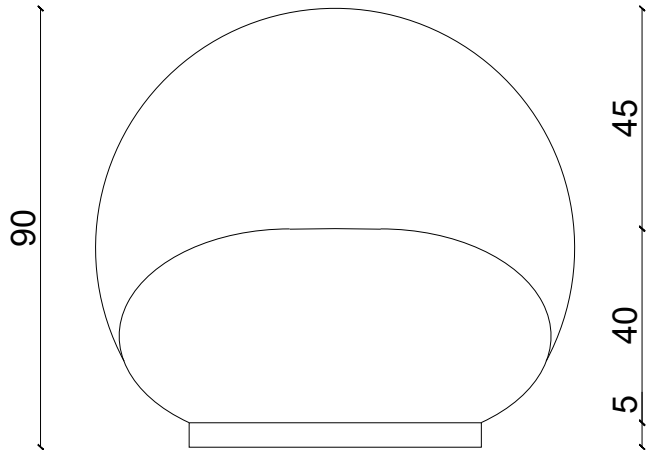
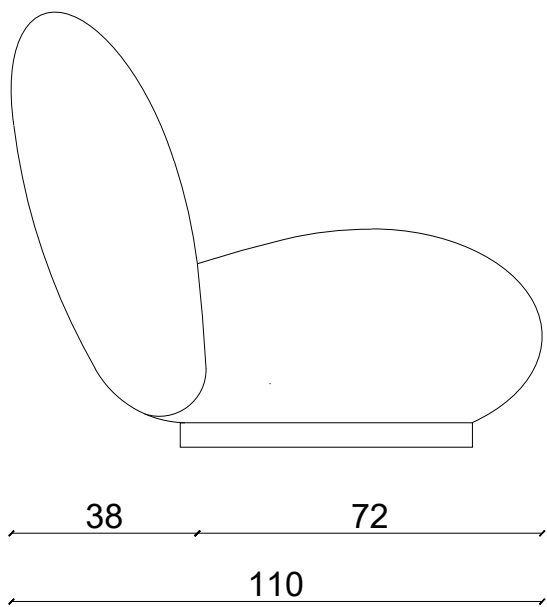

Prodotto

Snaked

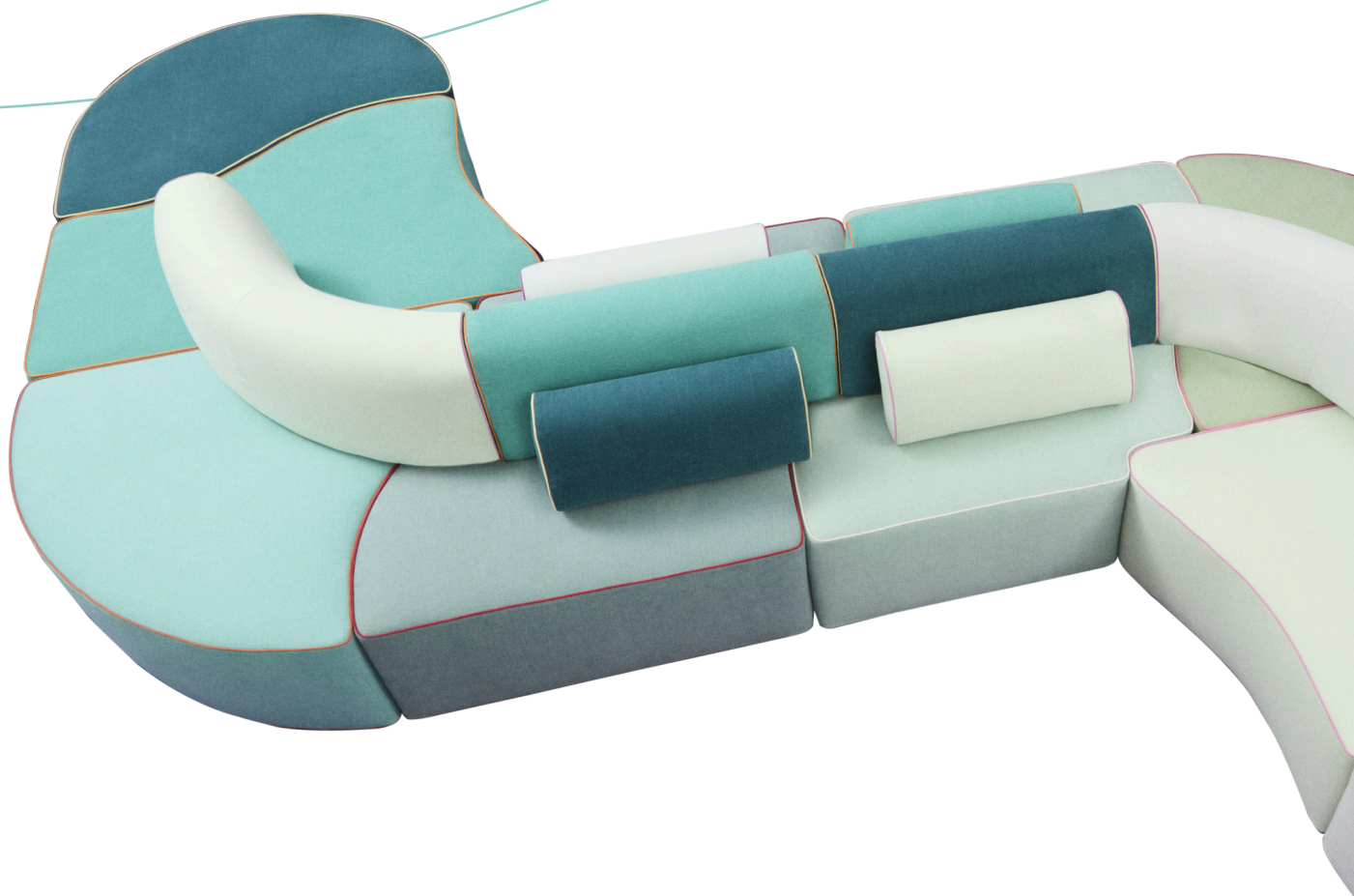

DESIGN
GIUSEPPE DICECCA

/CARATTERISTICHE

Snaked è un divano creato per poter far vivere gli 11 differenti moduli in migliaia di combinazioni e colori. Il processo creativo improntato sulle rotondità degli elementi è file-rouge che lega i moduli alla loro assemblabilità, concetto che permette di curare ogni specifica esigenza di spazio e forma.

I cuscini di spalliera sono autonomi e possono essere spostati e riposizionati al fine di creare e movimentare nuovi spazi.

Se per l'Indoor il suo comfort è curato da un'eccezionale gommapiuma ecosostenibile, per l'Outdoor è il Dryfeel® che la rende unica; Dryfeel® è una gommapiuma a struttura cellulare completamente aperta che consente all'acqua e all'umidità di passarvi attraverso in modo rapido ed efficace, assicurando il massimo confort in ogni condizione di umidità.

In versione Indoor presenta un tessuto è un 63 % cotone / 37 % Lino mentre in versione Outdoor si veste di 100% acrilico in 46 colori.







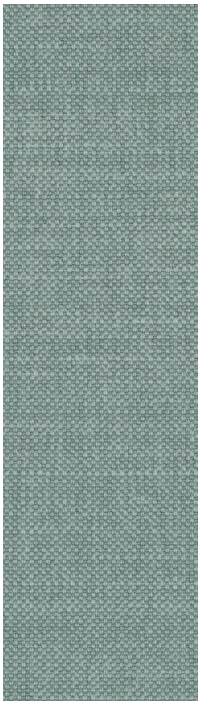



Materiali & Colori

KISS ME QUICK
(INDOOR)

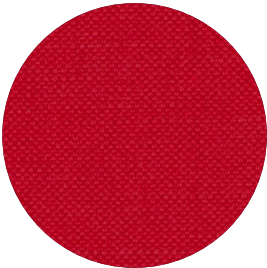

HM1249
011

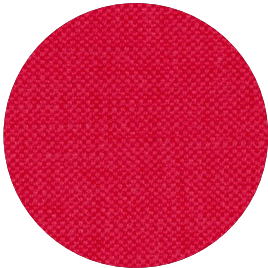

HM1249
012

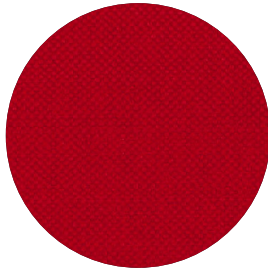

HM1249
013

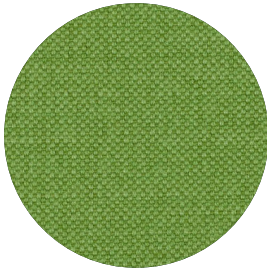

HM1249
038

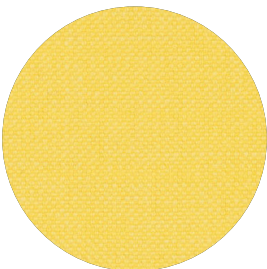

HM1249
045

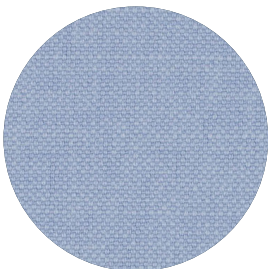

HM1249
059

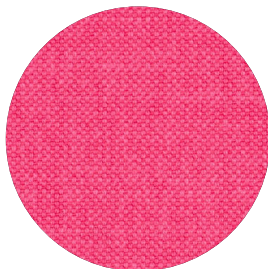

HM1249
063

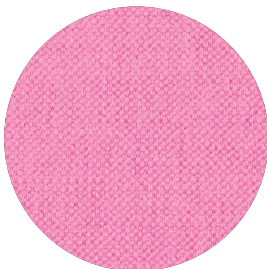

HM1249
064

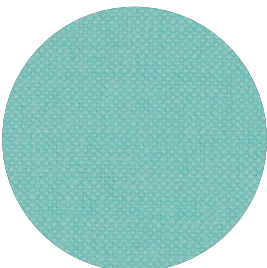

HM1249
088

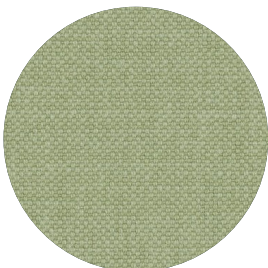

HM1249
089

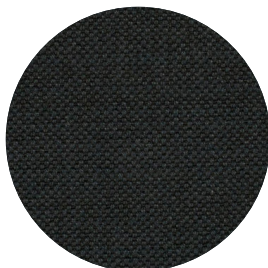

HM1249
099

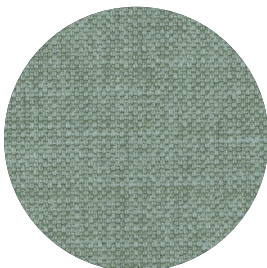

HM1249
103

Materiali & Colori

KISS ME QUICK
(INDOOR)

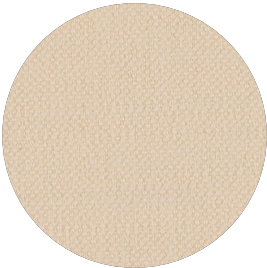

HM1249
131

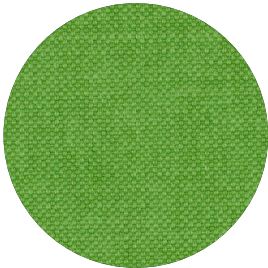

HM1249
139

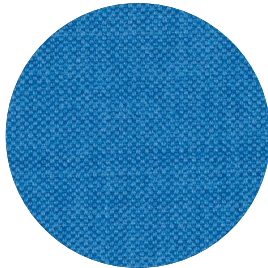

HM1249
155

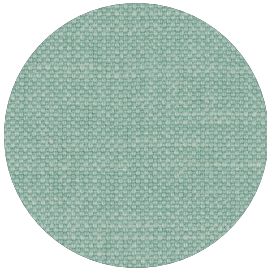

HM1249
180

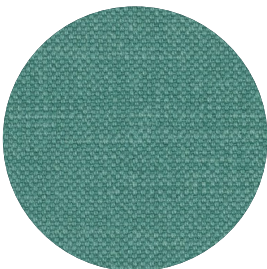

HM1249
181

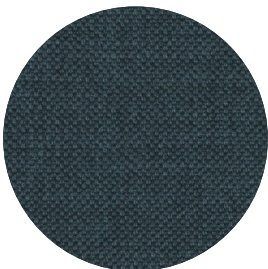

HM1249
182

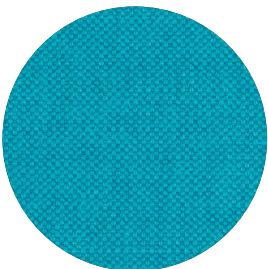

HM1249
184

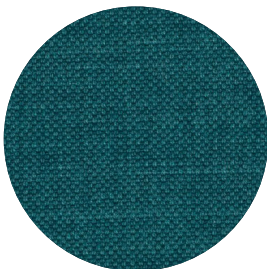

HM1249
185

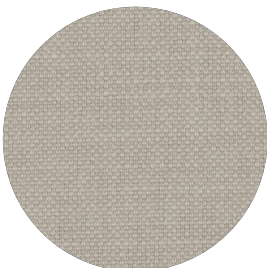

HM1249
192

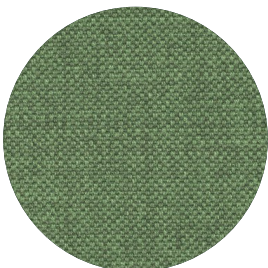

HM1249
232

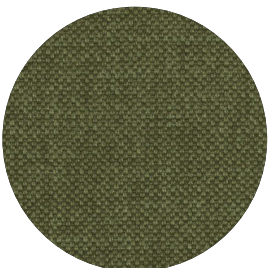

HM1249
234

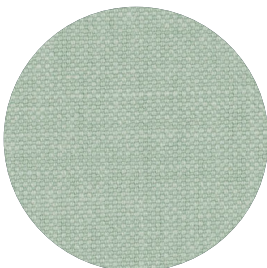

HM1249
248

Materiali & Colori

KISS ME QUICK
(INDOOR)

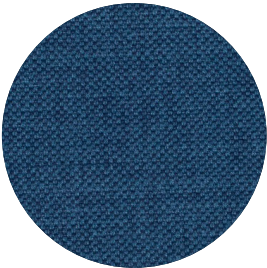

HM1249
499

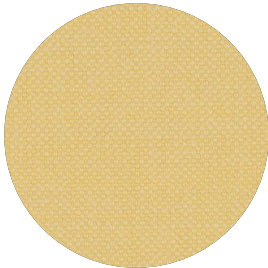

HM1249
509

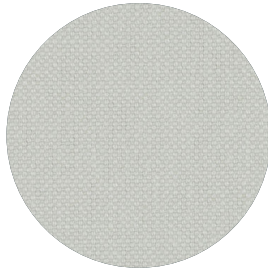

HM1249
517

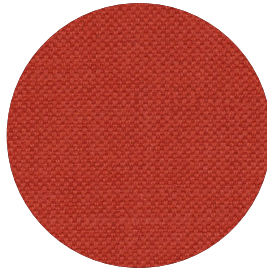

HM1249
521

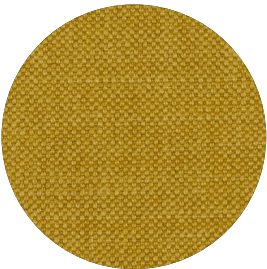

HM1249
528

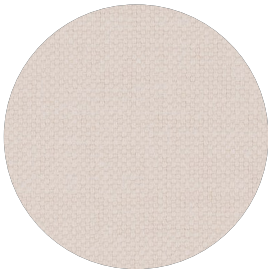

HM1249
560

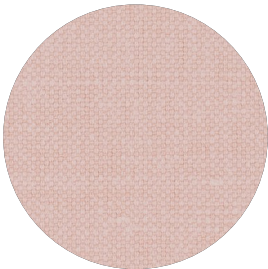

HM1249
561

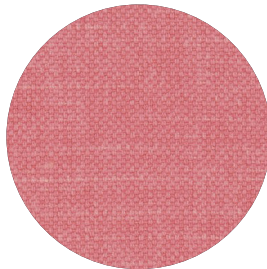

HM1249
566

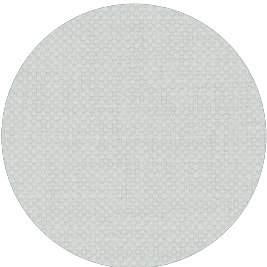

HM1249
608

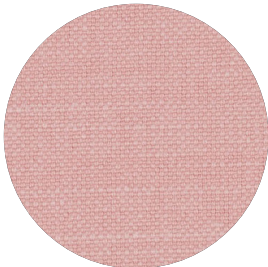

HM1249
697

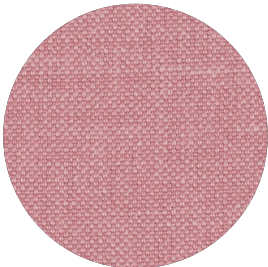

HM1249
698



HM1249
700

Materiali & Colori

KISS ME QUICK
(INDOOR)

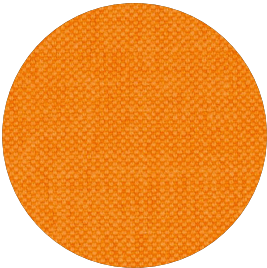

HM1249
702

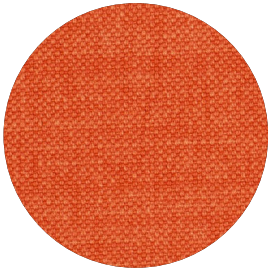

HM1249
703

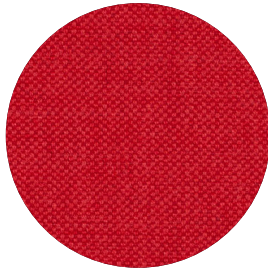

HM1249
704

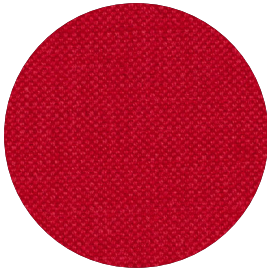

HM1249
705

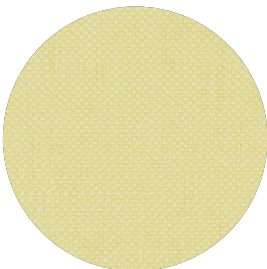

HM1249
707

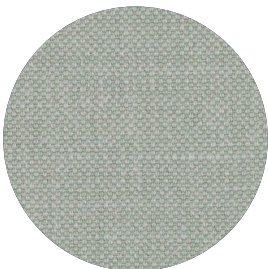

HM1249
717

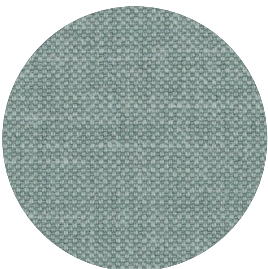

HM1249
722

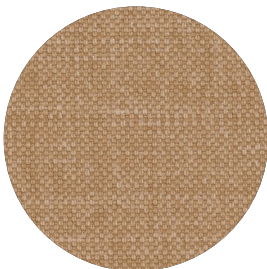

HM1249
727

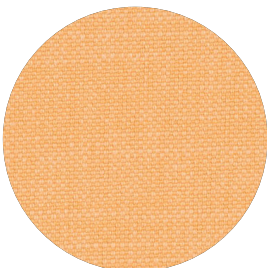

HM1249
896

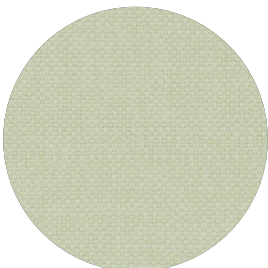

HM1249
935

Materiali & Colori

TUTTIFRUTTI
(OUTDOOR)



V02056
002



V02056
003



V02056
004

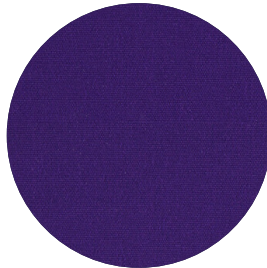

V02056
002

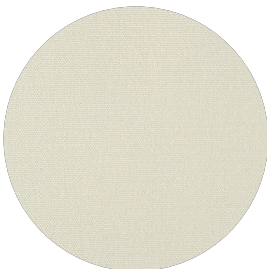

V02056
100



V02056
101



V02056
102



V02056
103



V02056
200



V02056
300

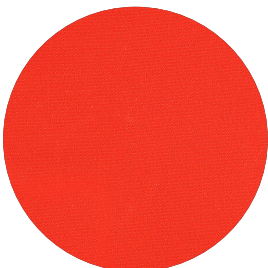

V02056
301

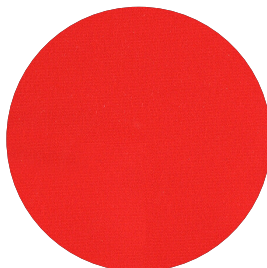

V02056
302

Materiali & Colori

TUTTIFRUTTI
(OUTDOOR)



V02056
303



V02056
305

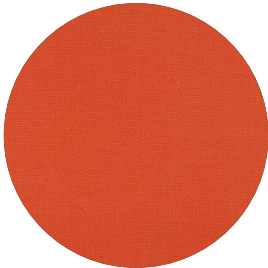

V02056
307

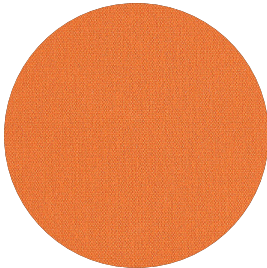

V02056
308

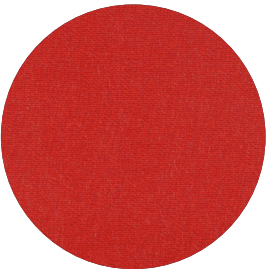

V02056
309



HM1249
400

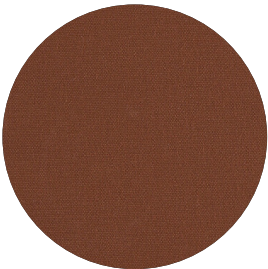

V02056
402



V02056
403

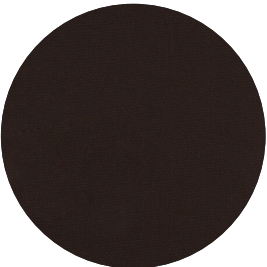

V02056
405



V02056
500



V02056
501

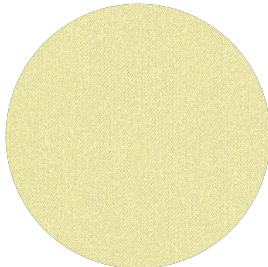

V02056
502

Materiali & Colori

TUTTIFRUTTI
(OUTDOOR)

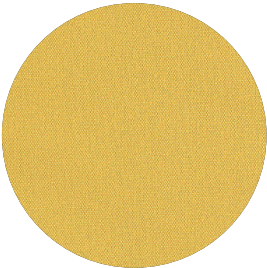

V02056
503

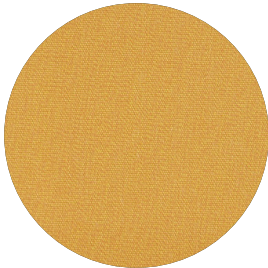

V02056
509

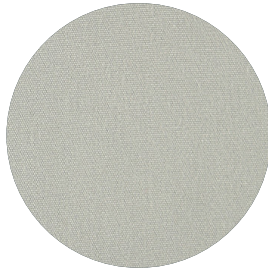

V02056
600

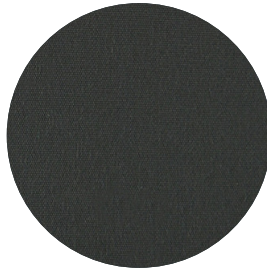

V02056
601

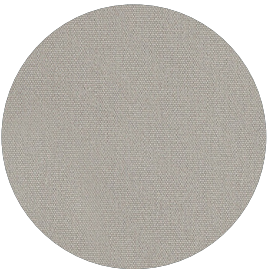

V02056
602

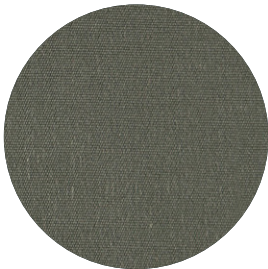

V02056
603

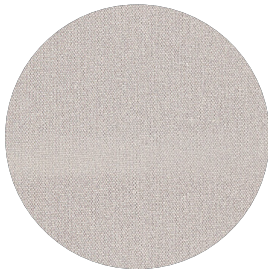

V02056
604



V02056
700



V02056
701

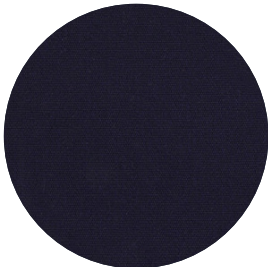

V02056
702

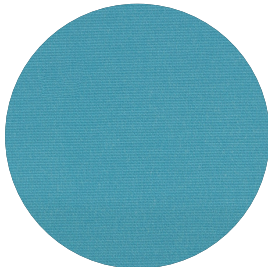

V02056
703

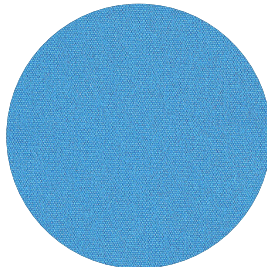

V02056
704

Materiali & Colori

TUTTIFRUTTI
(OUTDOOR)

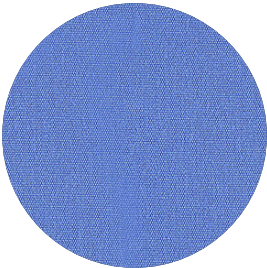

V02056
705

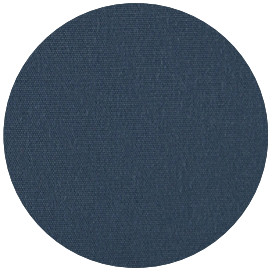

V02056
706

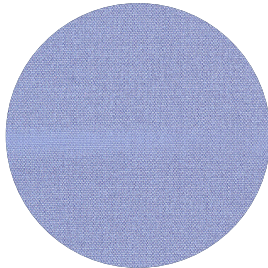

V02056
707

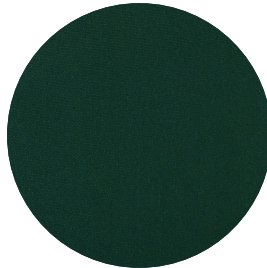

V02056
800

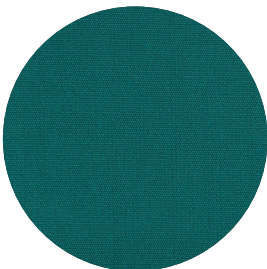

V02056
801

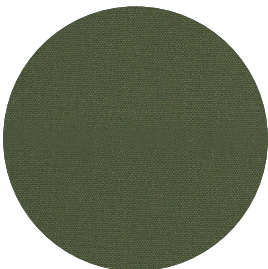

V02056
802



V02056
803

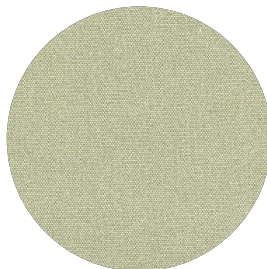

V02056
804

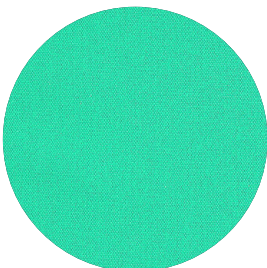

V02056
805

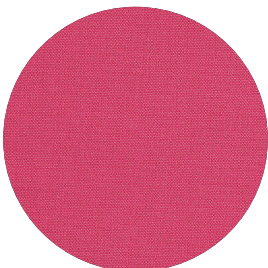

V02056
900

BLOCCO 1

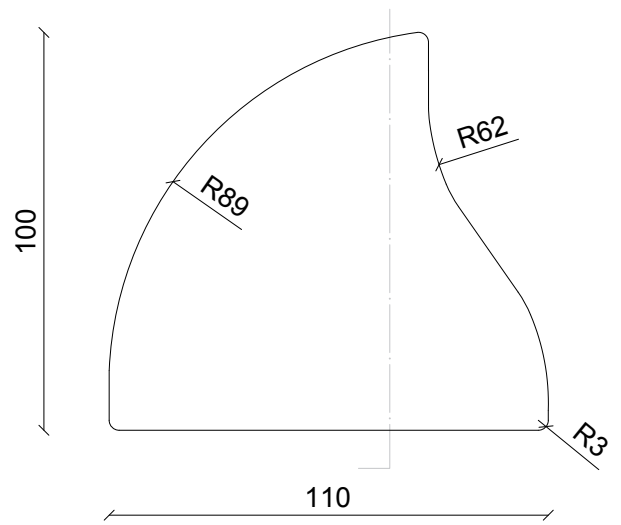
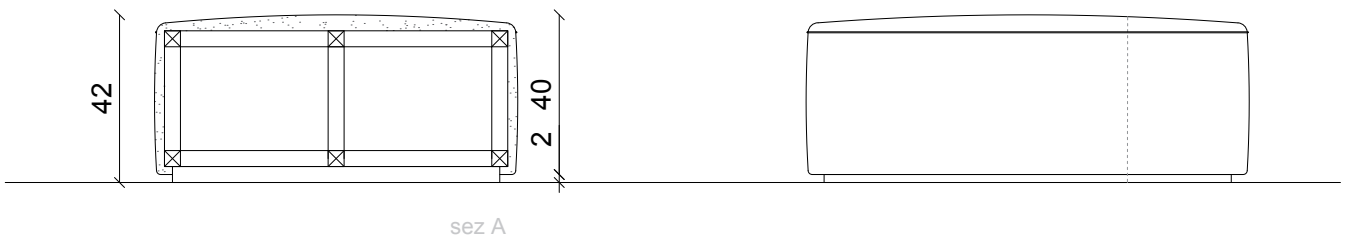

BLOCCO 2

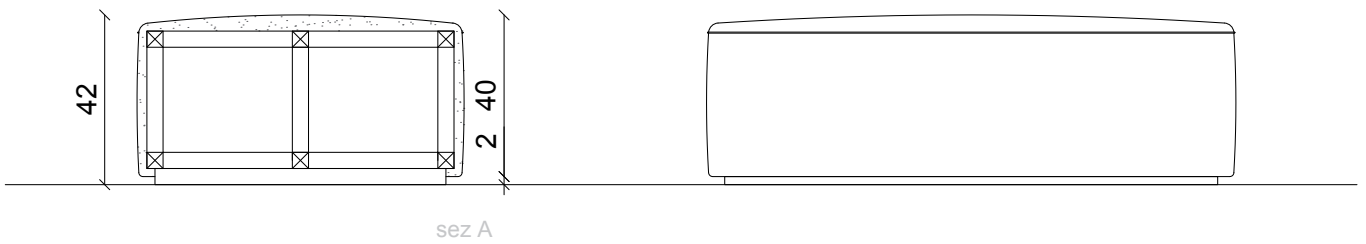

sez A

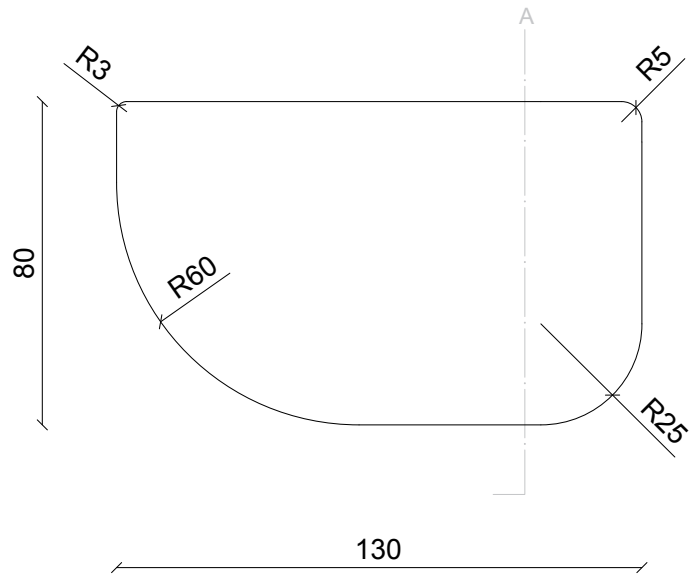

BLOCCO 3

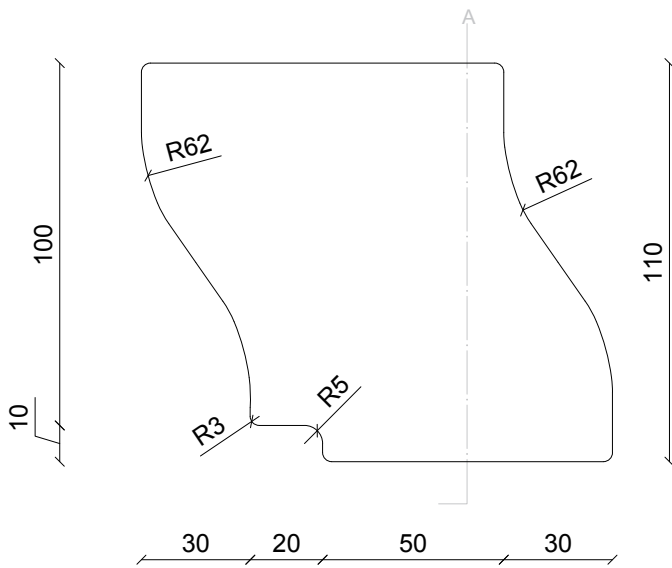
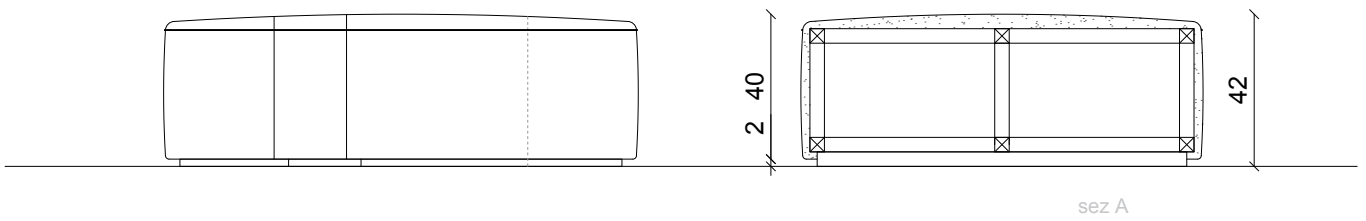

BLOCCO 4

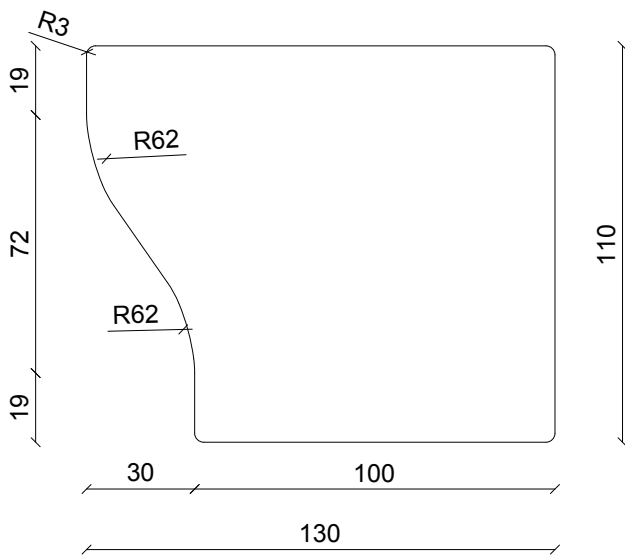
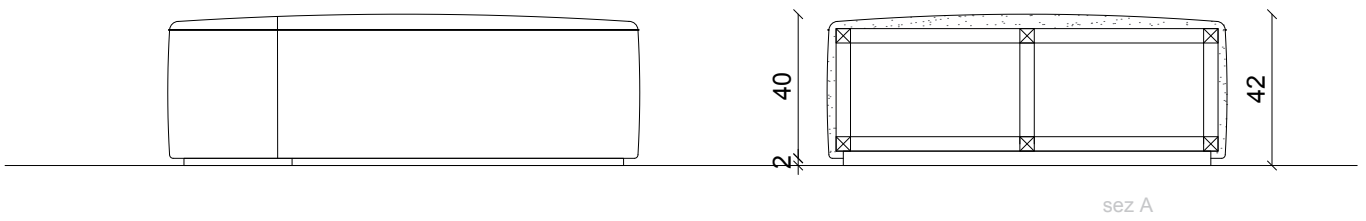

BLOCCO 5

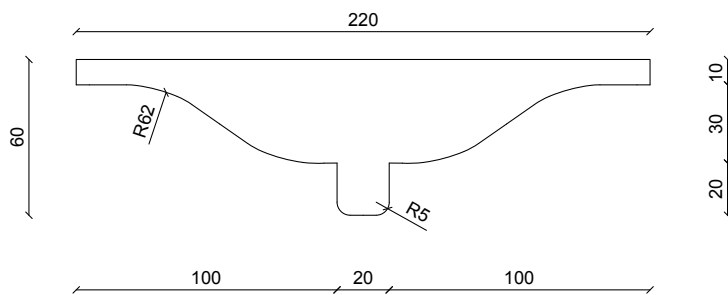
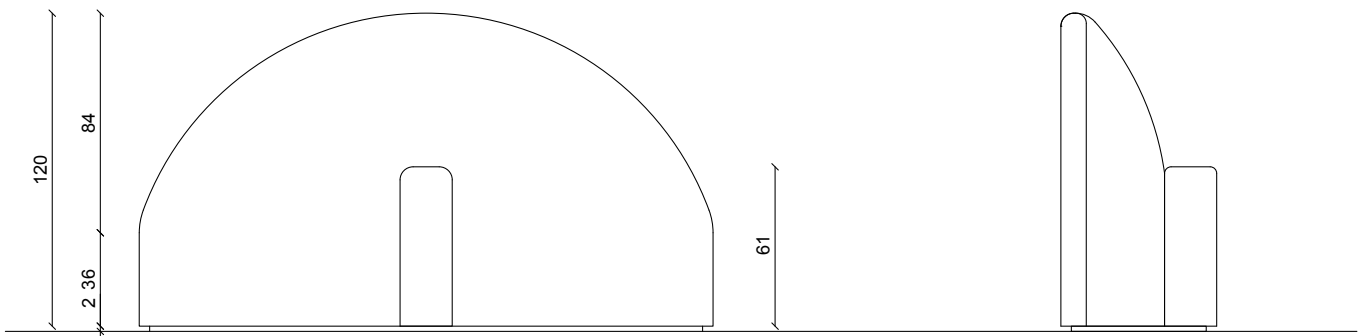

BLOCCO 6

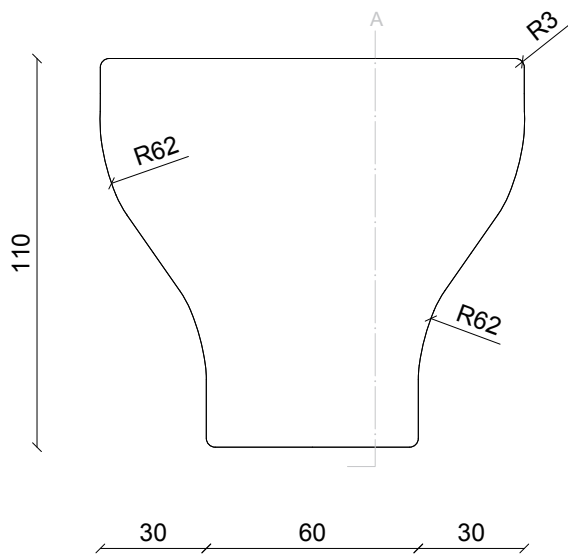
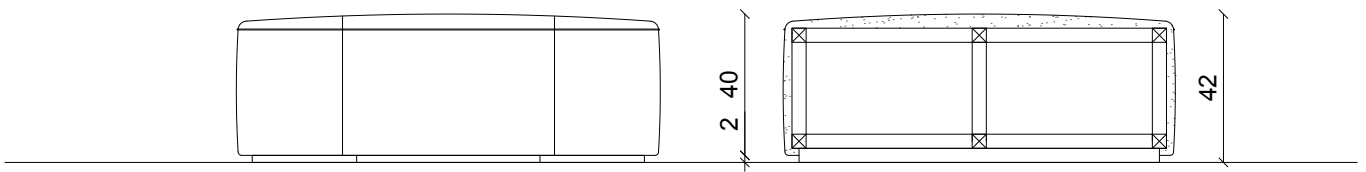

BLOCCO 7

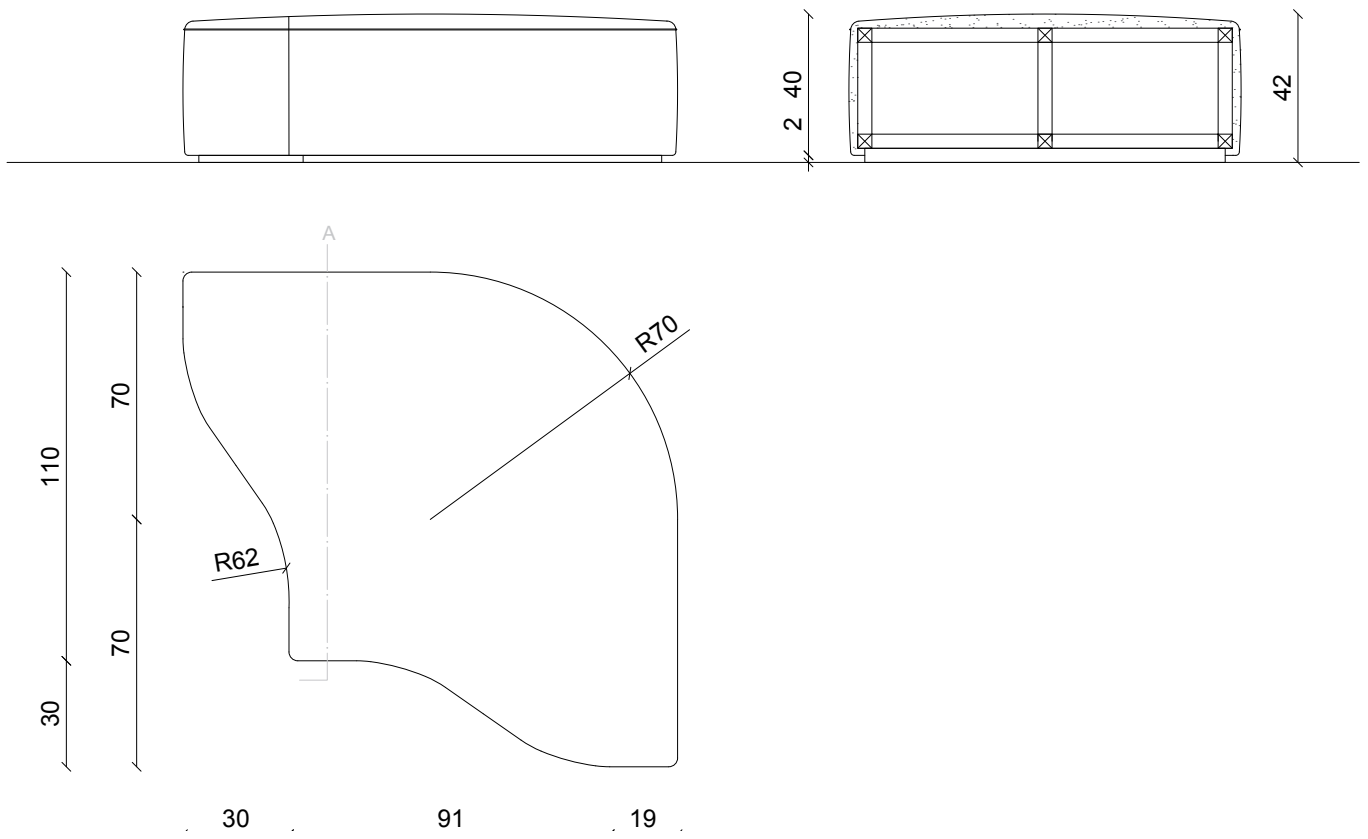

BLOCCO 8

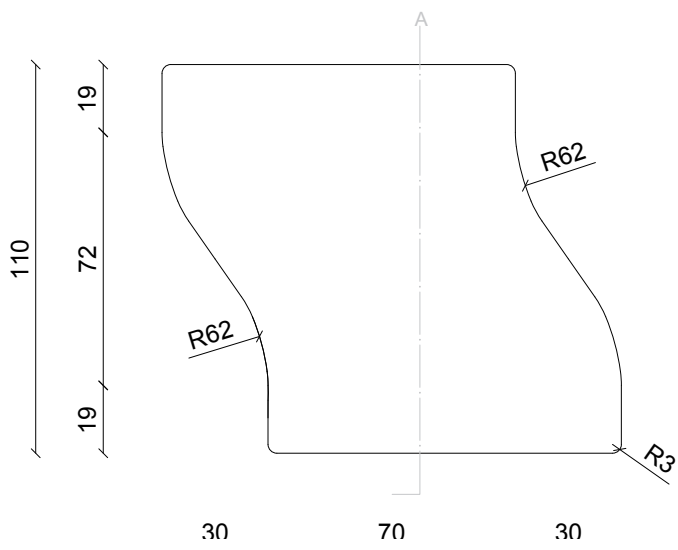
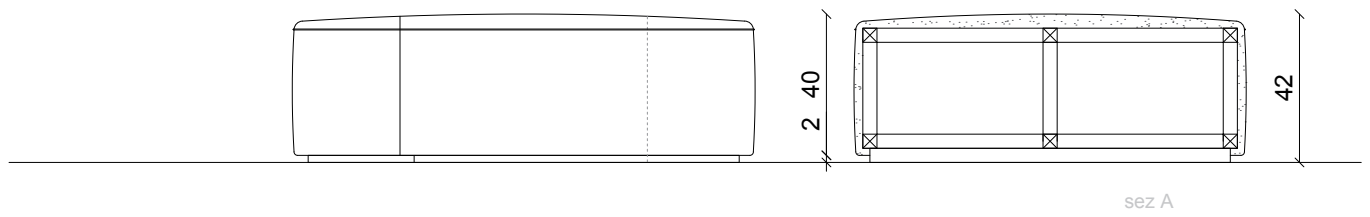

BLOCCO 9

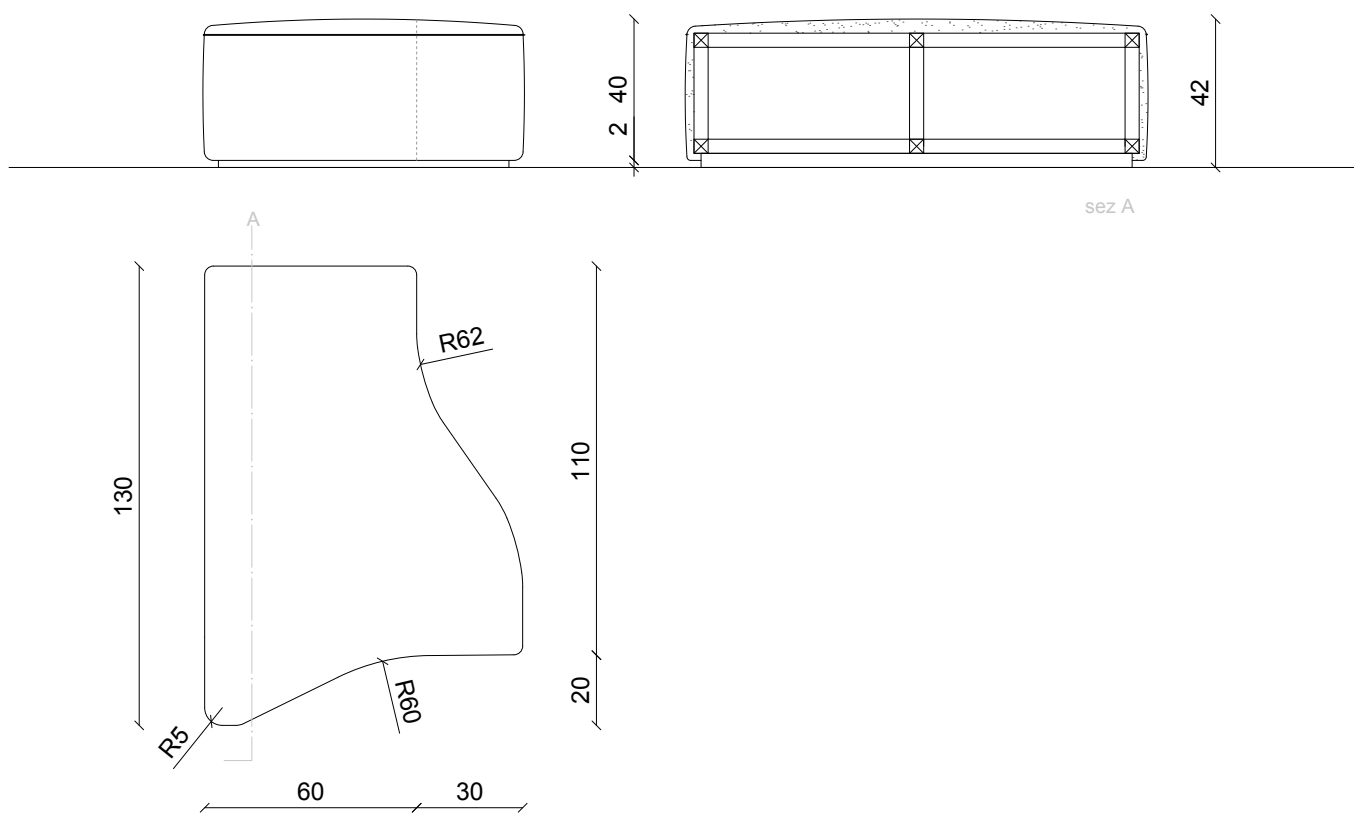

BLOCCO 10

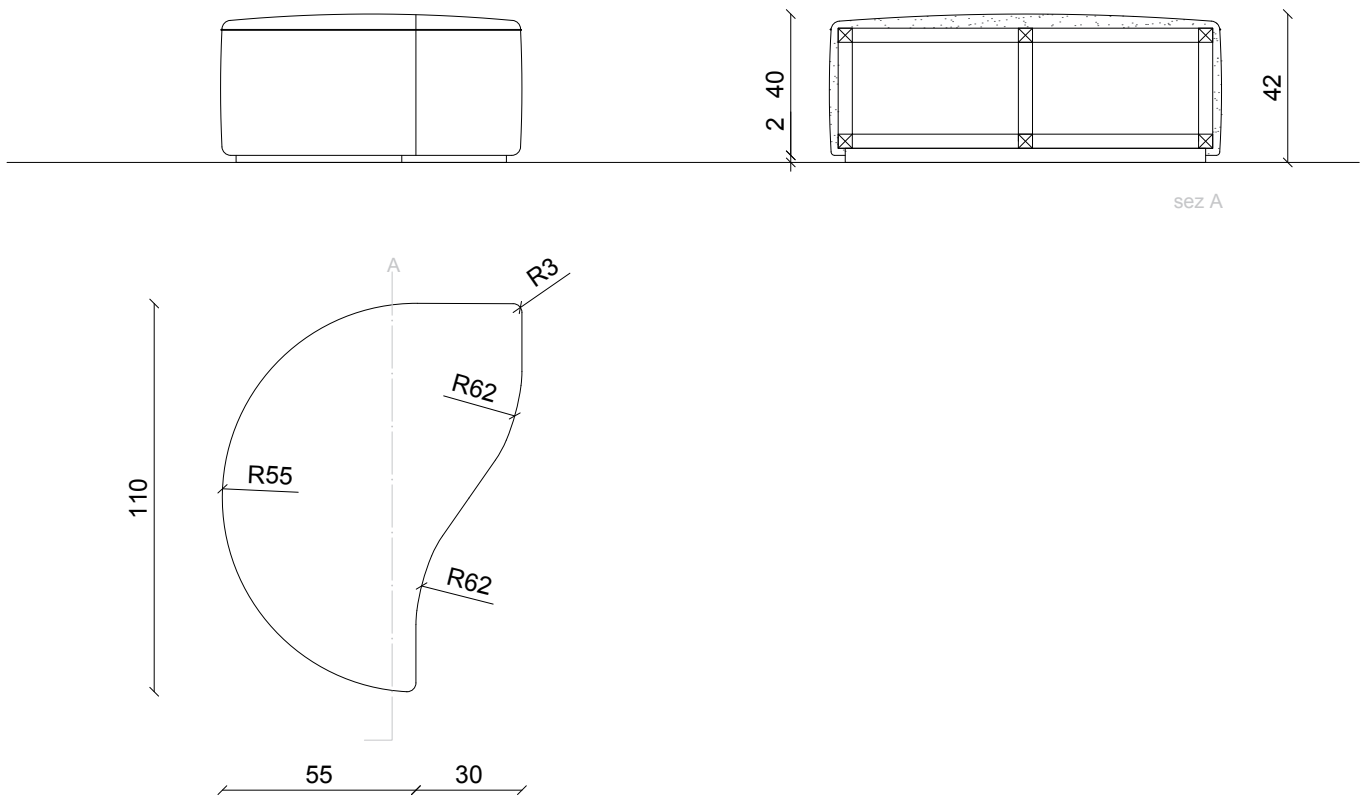

BLOCCO 11

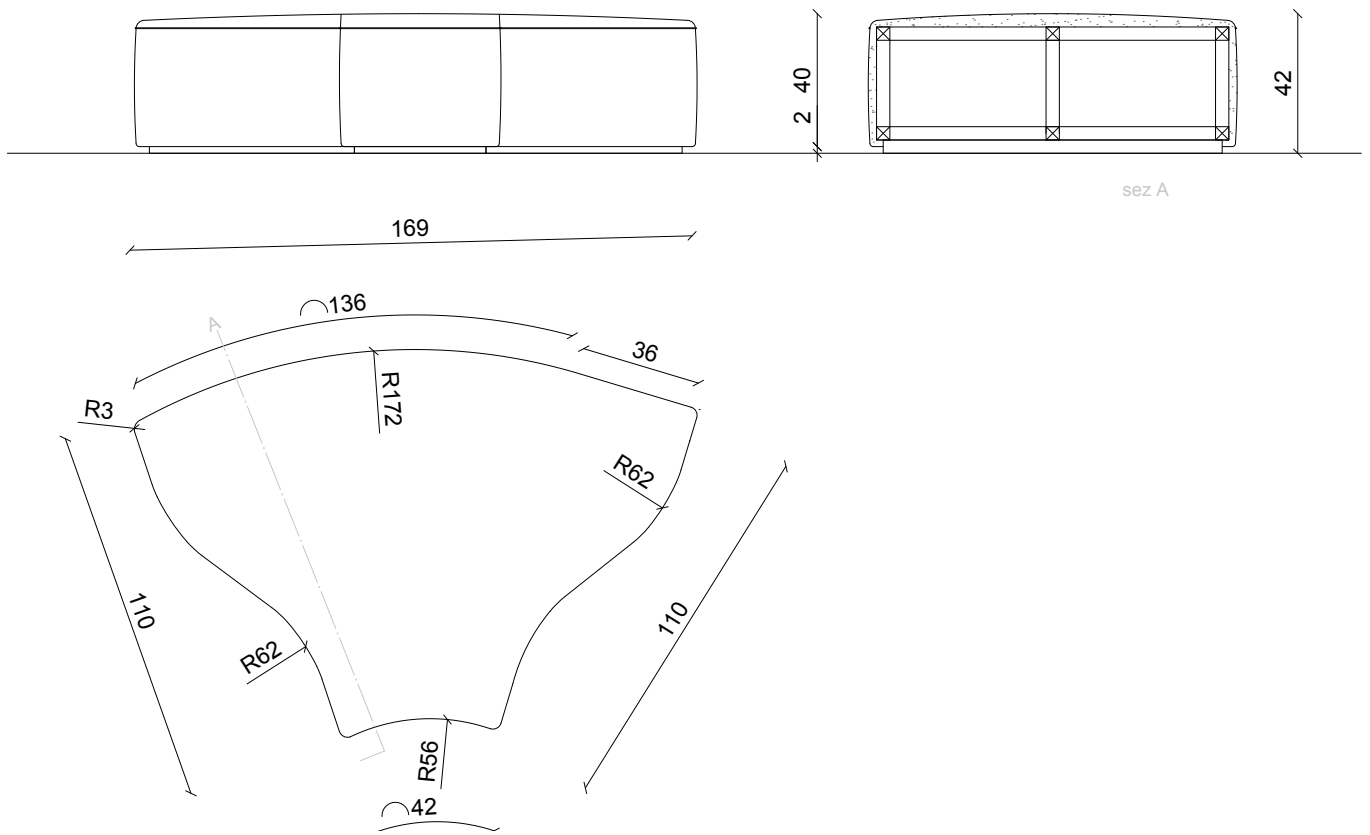

BLOCCO 12

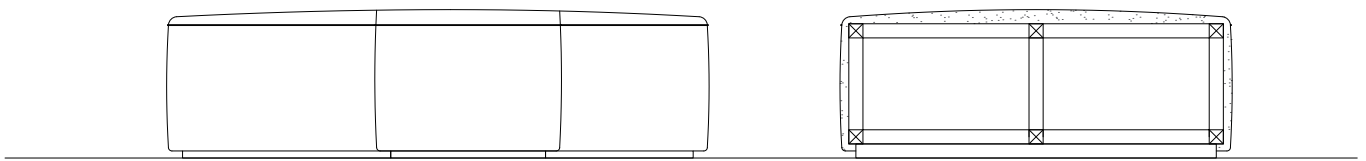

sez A

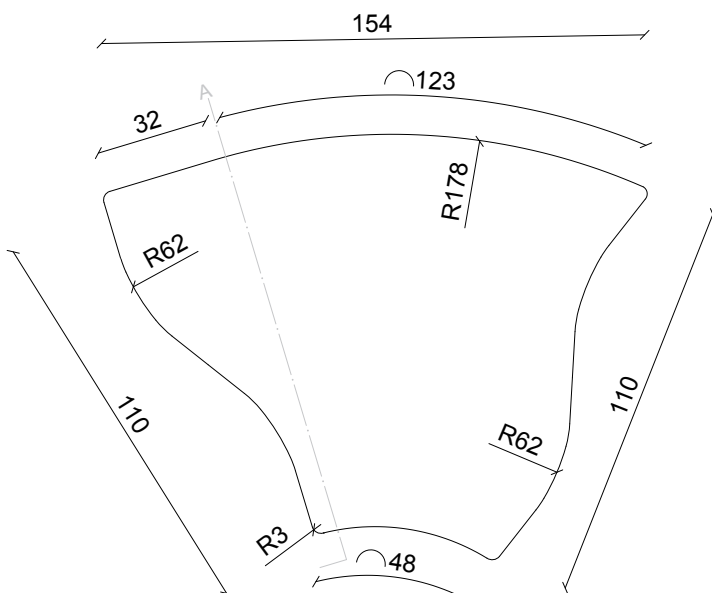

CUSCINI

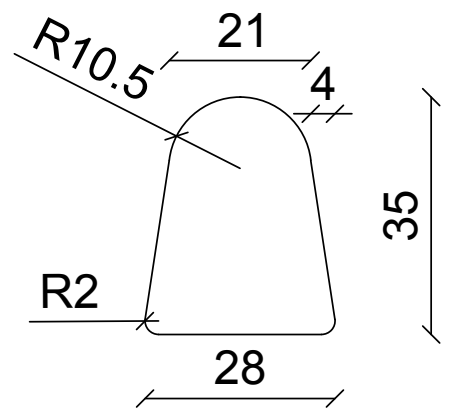
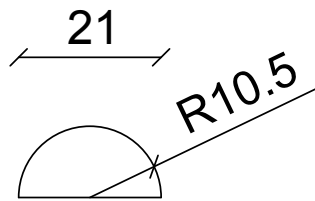
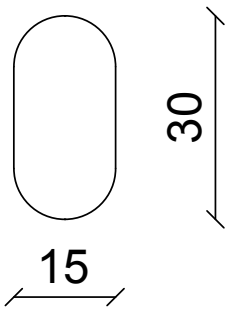

METÀ BLOCCO

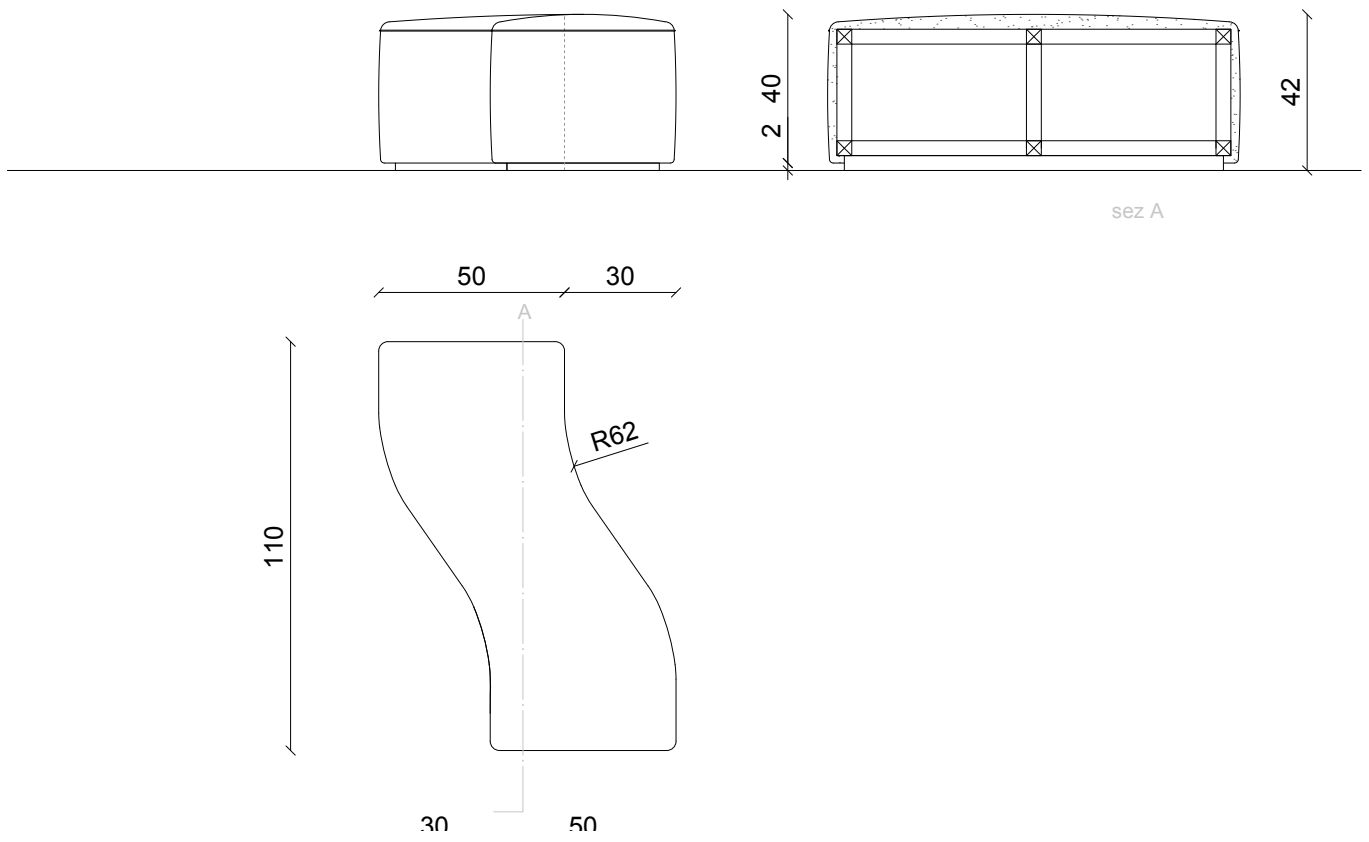

Prodotto

Misstake



**DESIGN
GIUSEPPE DICECCA**

/CARATTERISTICHE

Misstake è un ironico richiamo ad un errore nato nella costruzione del classico modello Chester.

La sua struttura è stata elaborata partendo dal concetto classico donando un allure contemporaneo ed inusuale, puntando su una sfumatura creata dall'asimmetria.

Il gioco di colori è dato dall' inserimento di bottoni in contrasto che donano una tono pop a questa irregolare creazione.

Prodotto con la massima ecosostenibilità, il tessuto è un velluto 50% cotone, 50% modal con una cartella colori ricca ed audace per poter creare inusuali contrasti.

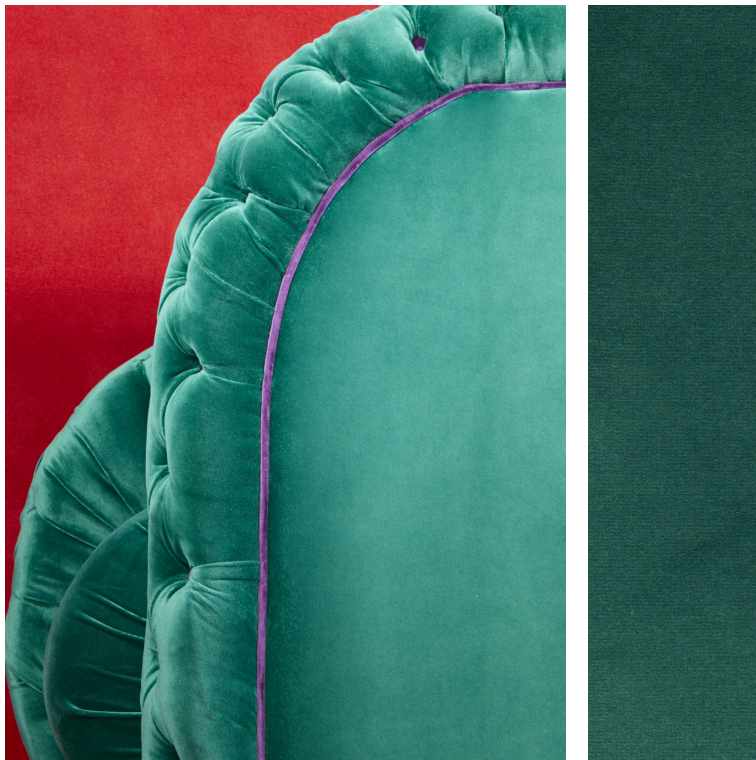
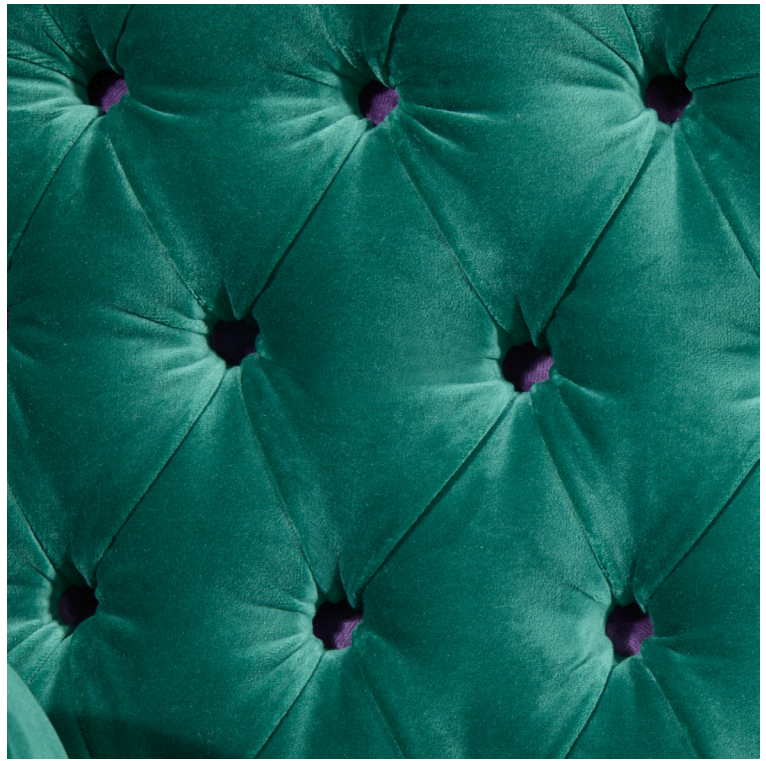



Materiali & Colori

LOVE LETTERS

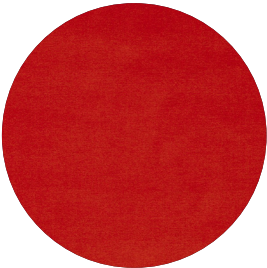

VV1320
010

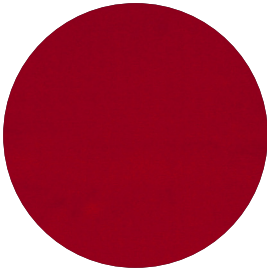

VV1320
011

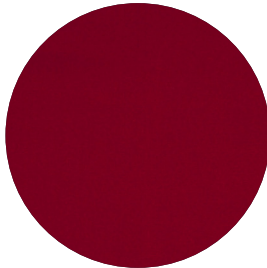

VV1320
012

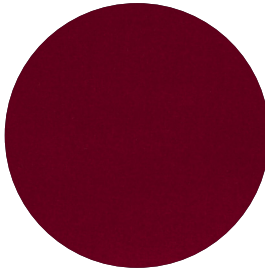

VV1320
013



VV1320
014

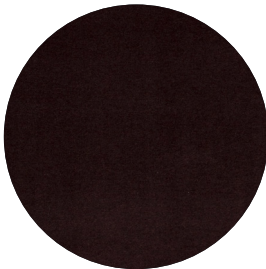

VV1320
015

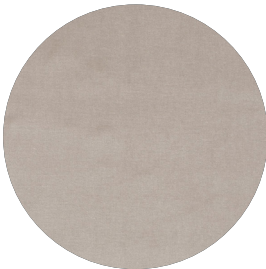

VV1320
020



VV1320
021

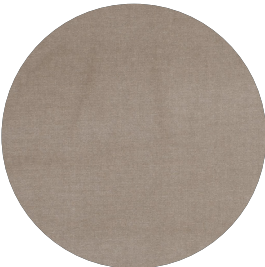

VV1320
022

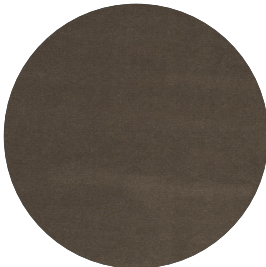

VV1320
023



VV1320
024



VV1320
025

Materiali & Colori

LOVE LETTERS



VV1320
026

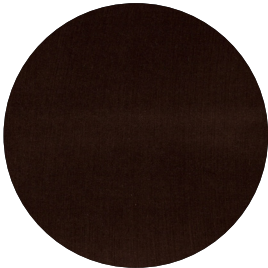

VV1320
027



VV1320
028



VV1320
029

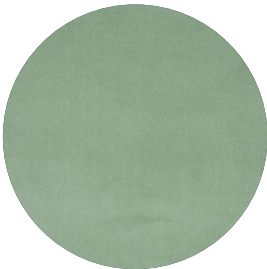

VV1320
030



VV1320
031



VV1320
032



VV1320
033



VV1320
034



VV1320
035

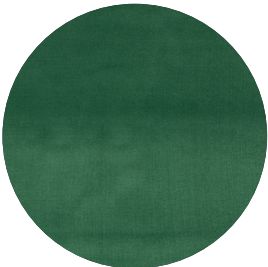

VV1320
036



VV1320
037

Materiali & Colori

LOVE LETTERS



VV1320
038



VV1320
039



VV1320
040



VV1320
041

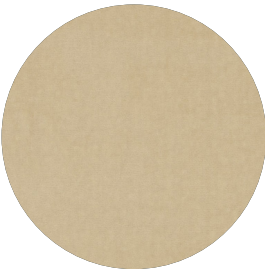

VV1320
042



VV1320
043



VV1320
044

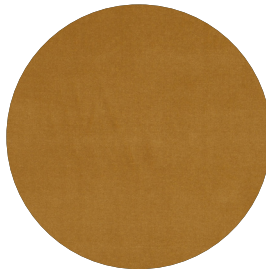

VV1320
045



VV1320
046



VV1320
047

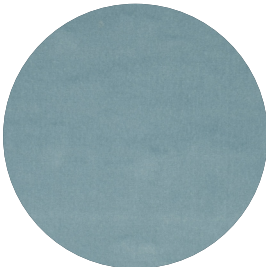

VV1320
050

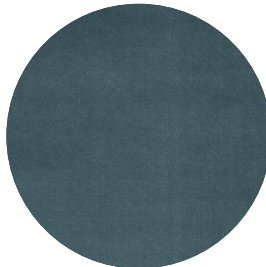

VV1320
051

Materiali & Colori

LOVE LETTERS

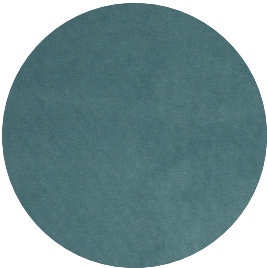

VV1320
052

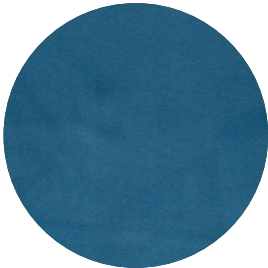

VV1320
053

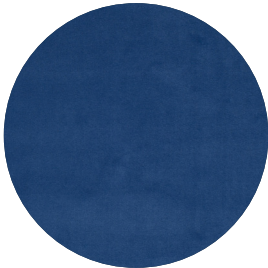

VV1320
054



VV1320
055

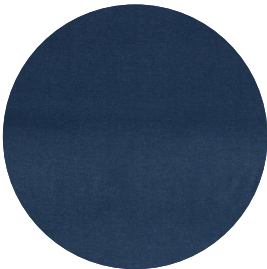

VV1320
056



VV1320
057

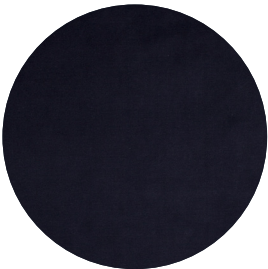

VV1320
058

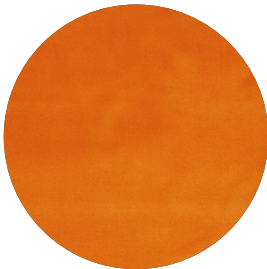

VV1320
060

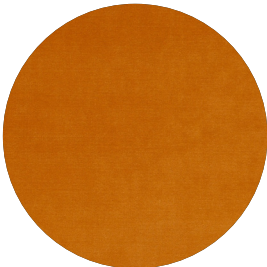

VV1320
061



VV1320
063



VV1320
064



VV1320
065

Materiali & Colori

LOVE LETTERS



VV1320
066

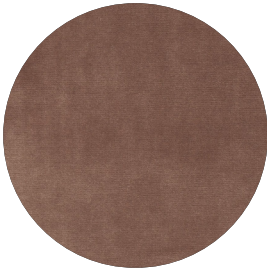

VV1320
067

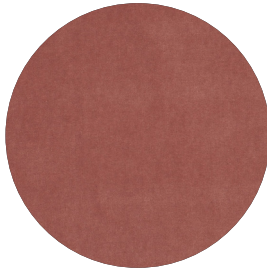

VV1320
068

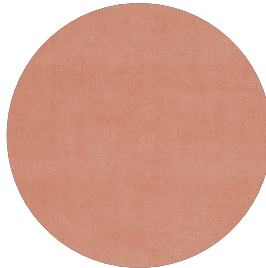

VV1320
069



VV1320
070



VV1320
071



VV1320
072



VV1320
073

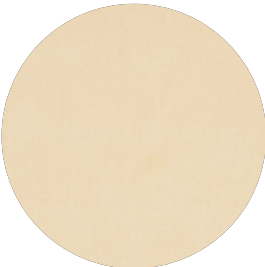

VV1320
074

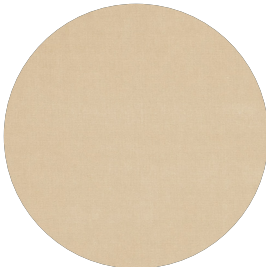

VV1320
075



VV1320
076



VV1320
077

Materiali & Colori

LOVE LETTERS

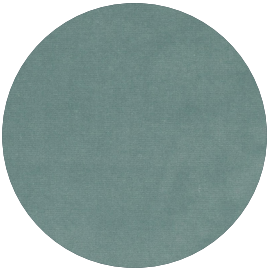

VV1320
080

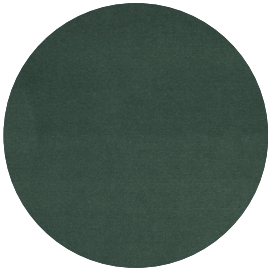

VV1320
081

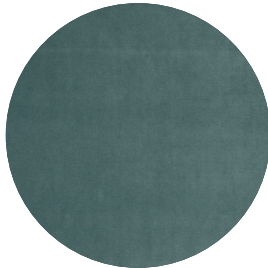

VV1320
082



VV1320
083

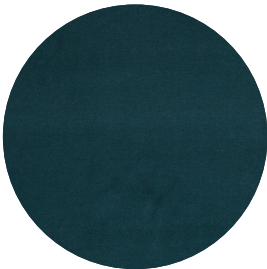

VV1320
084



VV1320
085



VV1320
086

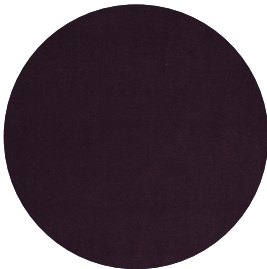

VV1320
087



VV1320
088

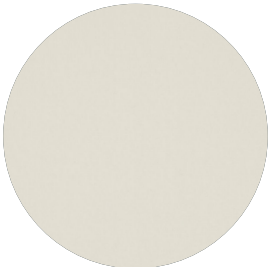

VV1320
090

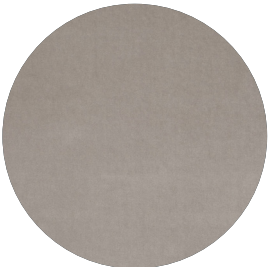

VV1320
091

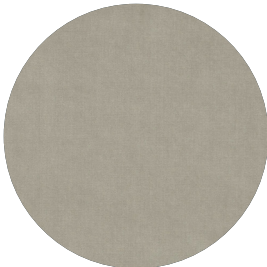

VV1320
092

Materiali & Colori

LOVE LETTERS

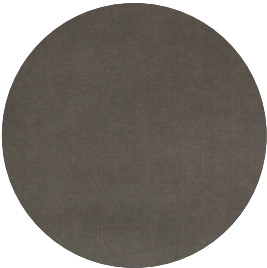

VV1320
093

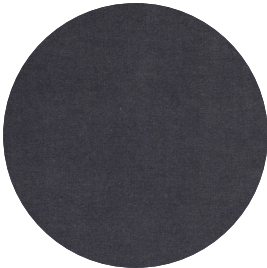

VV1320
094

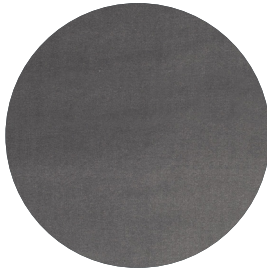

VV1320
095

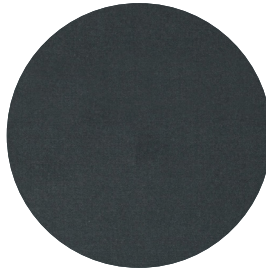

VV1320
096

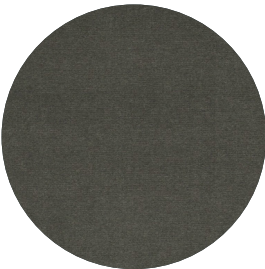

VV1320
097

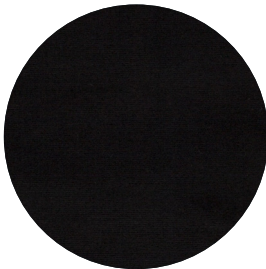

VV1320
099



VV1320
130



VV1320
131



VV1320
132

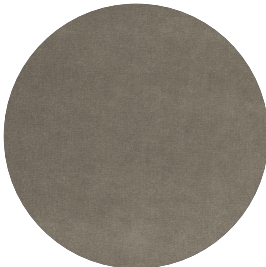

VV1320
133

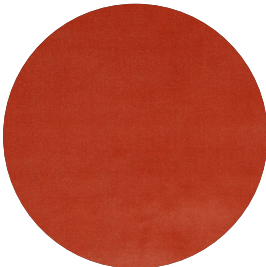

VV1320
160



VV1320
161

Materiali & Colori

LOVE LETTERS

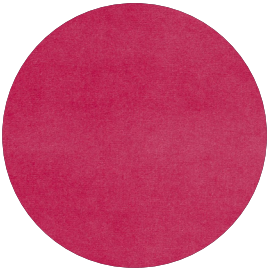

VV1320
162

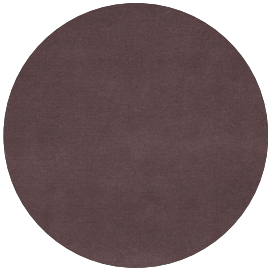

VV1320
163

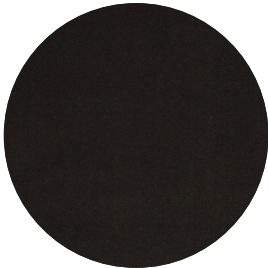

VV1320
190



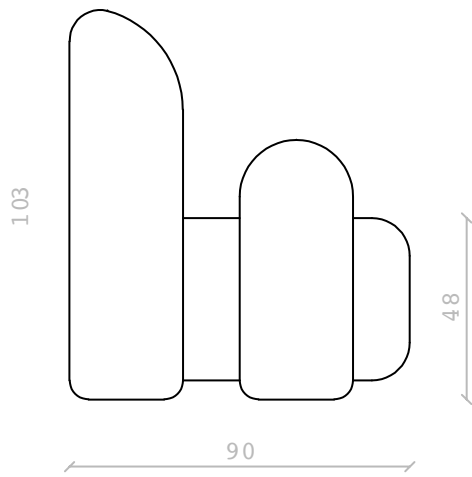
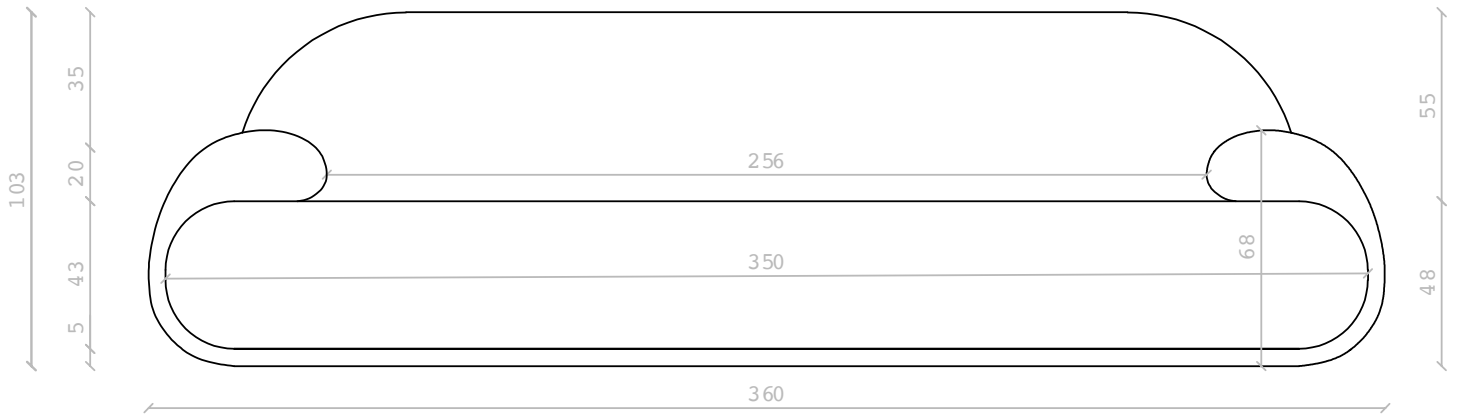

Prodotto

Jimmy



DESIGN
GIUSEPPE DICECCA

/CARATTERISTICHE

La chiara ispirazione anni '50 porta all' ideazione dello sgabello Jimmy, versatile, divertente e dall' anima vintage. Marchio di fabbrica del Jimmy sono i suoi morbidi cilindri curvi che accolgono il "ben capitato" in una seduta sostenuta e confortevole.

Disponibile in velluto con 16 varianti colore.



Materiali & Colori

MY BABE



TV1578
021



TV1578
030



TV1578
031

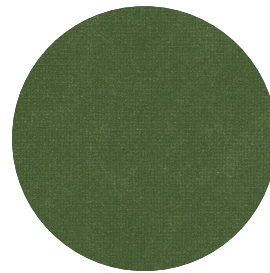

TV1578
032

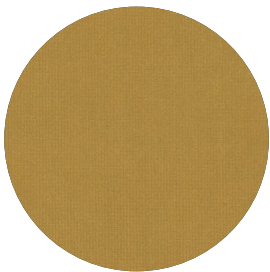

TV1578
041



TV1578
043

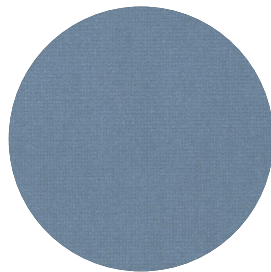

TV1578
051

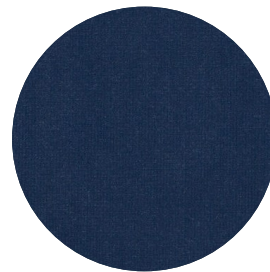

TV1578
052

Materiali & Colori

MY BABE

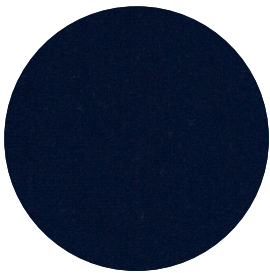

TV1578
053

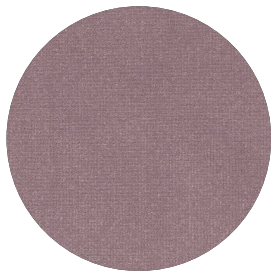

TV1578
061

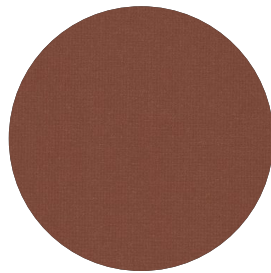

TV1578
064

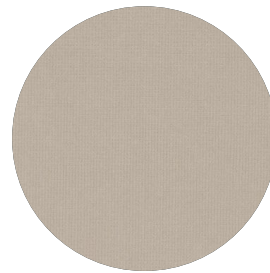

TV1578
073

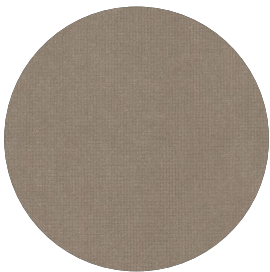

TV1578
076



TV1578
083

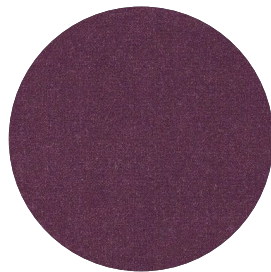

TV1578
084

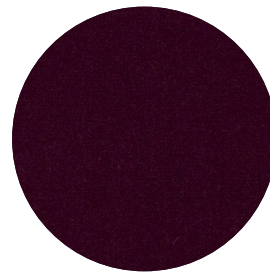

TV1578
085

85 22

23 2 52 8 10 12

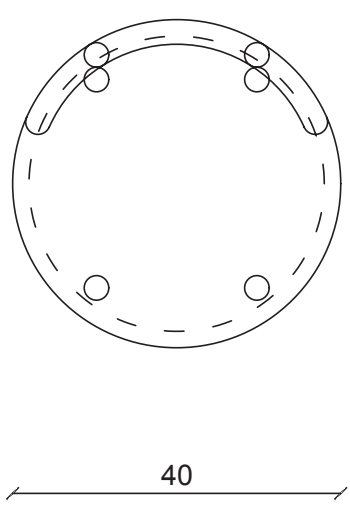
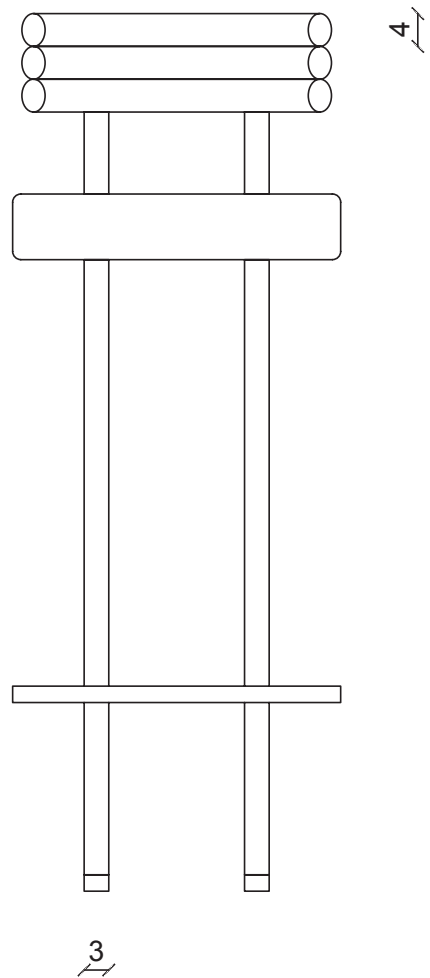

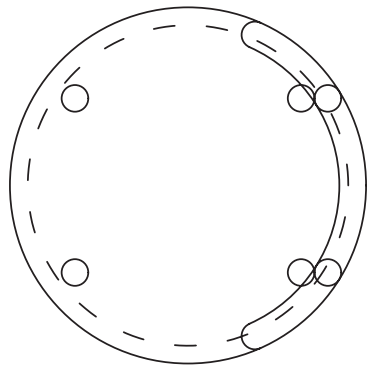
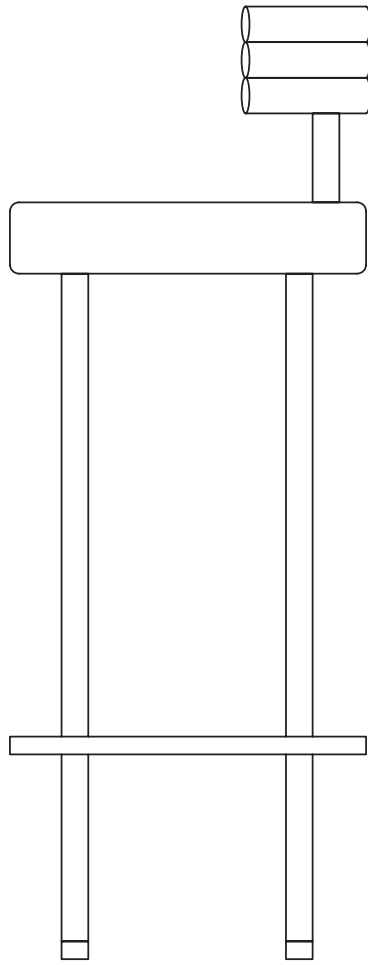

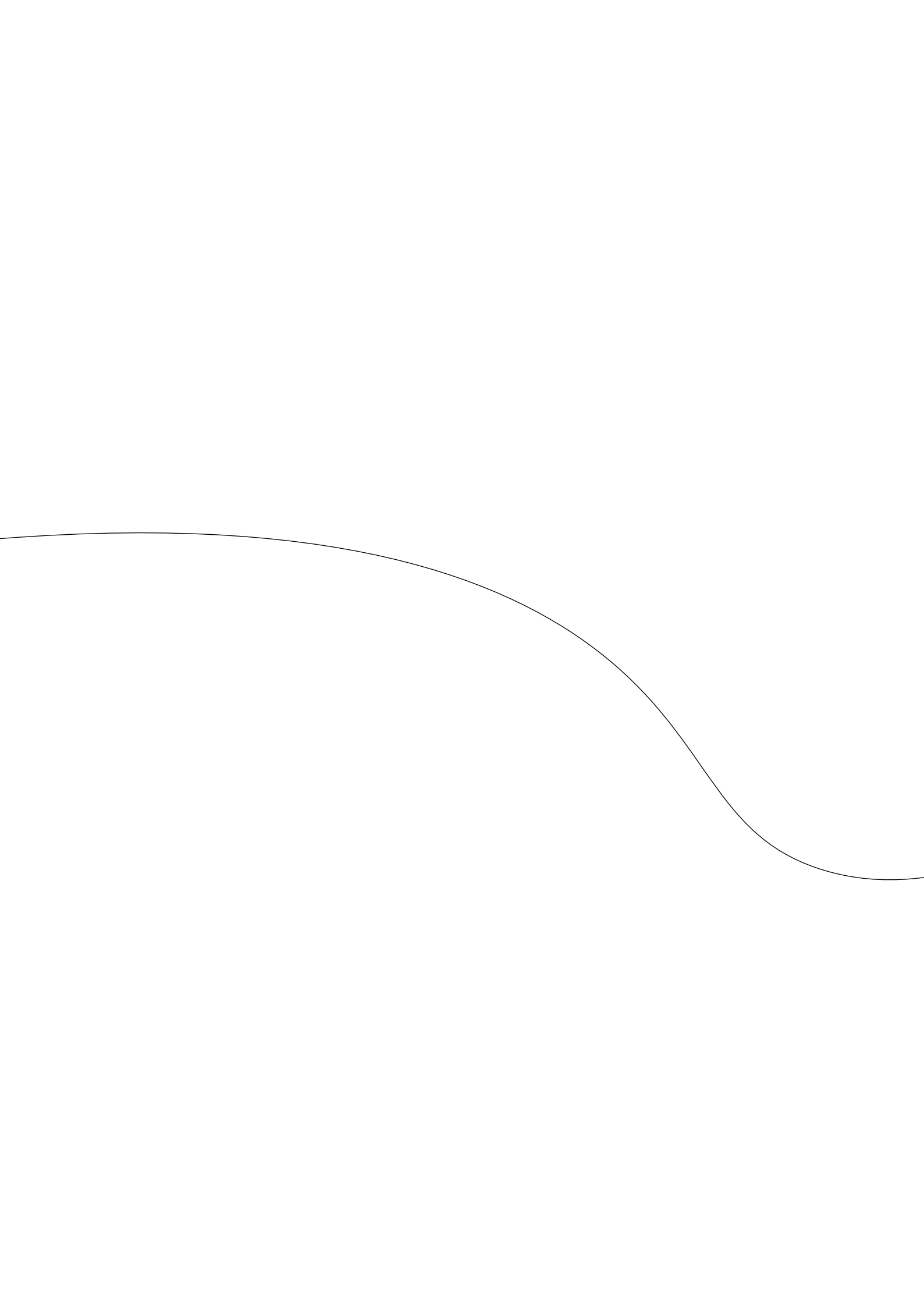

PAOLONESI

F I R E N Z E 1 9 6 2

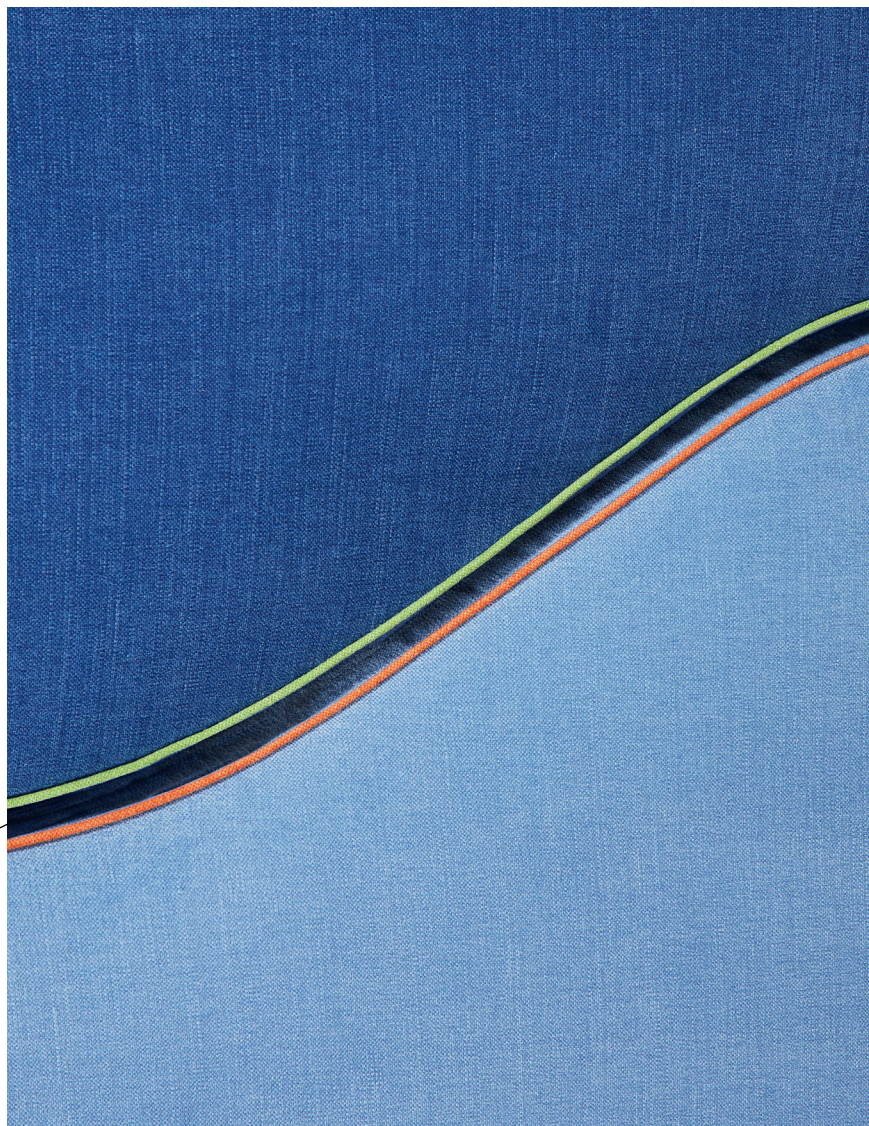

Sede legale: Località Drove 1 - 53036 Poggibonsi (SI)
Showroom Milano: Via Carlo de Angeli 3, 20141 Milano (MI)

Sito: paolonesi.it

Instagram: [paolonesi_official](https://www.instagram.com/paolonesi_official)

Facebook: Paolo Nesi

WhatsApp: +39 3420176837

Contatti: +39 (0)577979587 - info@paolonesi.it